

# WIRING STRATEGIES

## FOR VOICE AND DATA SYSTEMS



Interior  
Core  
Elevators

# TABLE OF CONTENTS

Wiring Strategies –Voice and Data Systems

## 1

### BOOK 1 TELECOMMUNICATIONS STANDARDS OVERVIEW

EIA/TIA Standards Overview .....	1-1	Other Important Information .....	1-5
The Category Rating System for Unshielded Twisted Pair .....	1-2	Safety and Installation Information .....	1-6
Specifications for Levels, Categories and Emerging Standards .....	1-3		
Other Network Applications—150Ω STP, 100VG-ANYLAN, 100Base-T, GigaBit Ethernet, 1000Base-T, ATM .....	1-4		

## 2

### BOOK 2 RESIDENTIAL AND LIGHT COMMERCIAL INSTALLATIONS (THE TIA-570 STANDARD)

Wiring Overview—Circuits, Polarity, Color Codes...	2-1
Installation Practices .....	2-3
Tips on Quality Installations .....	2-9
Residential Wiring Diagrams .....	2-10

### BOOK 2T TESTING & TROUBLESHOOTING RESIDENTIAL AND LIGHT COMMERCIAL WIRING SYSTEMS

Tools .....	2-13
Rough-In Wiring Tests .....	2-15
Final Verification Testing .....	2-18
Testing Security Systems .....	2-19

## 3

### BOOK 3 COMMERCIAL INSTALLATIONS (THE TIA 568-A STANDARD)

Benefits of TIA-568-A Compliance .....	3-1
100Ω UTP Cabling Systems .....	3-6
150Ω STP Cabling Systems .....	3-9
Telecommunications Closets .....	3-11
Cabling System Administration (TIA-606) .....	3-13
Do/Don't Installation Photos .....	3-15

### BOOK 3-T TESTING CATEGORY 5 WIRING SYSTEMS (TSB-67)

Overview .....	3-19
Testing Benefits .....	3-19
Definition of Channel vs. Link .....	3-19

## 4

### BOOK 4 FIBER OPTIC INSTALLATIONS (THE TIA-568-A STANDARD)

Overview of Fiber Optic Technology .....	4-1
Fiber Cable Construction .....	4-2
Optical Fiber Transmission .....	4-3
Installing Optical Cable .....	4-4
Handling Fiber Optic Cable .....	4-5
Fiber Optic Cable Termination .....	4-6
Fiber Connectors .....	4-7
CrossConnect Panels & Workstation Outlets .....	4-10

### BOOK 4-T FIBER OPTIC TESTING & TROUBLESHOOTING (TIA-568-A AND TIA-526-14, METHOD B)

System Verification Testing .....	4-13
Test Equipment .....	4-13
Required Tests .....	4-13
Testing Procedure .....	4-13
Bandwidth Verification .....	4-14
Other Things To Do Before Start-Up .....	4-14
Troubleshooting .....	4-14

### APPENDICES

Appendix A: Glossary of Terms from 'ATM' to 'UTP'
Appendix B: Network Diagrams
Appendix C: Jack Pin Designations & Color Codes

Appendix D: USOC Color Codes
Appendix E: Standards Document Contact Information
Appendix F: Product Ordering Guide

## BOOK 1

### OVERVIEW TIA Wiring STANDARDS

## BOOK 2

### RESIDENTIAL AND LIGHT COMMERCIAL APPLICATIONS

#### EIA/TIA 570

Compliant  
Installation

## BOOK 3

### COPPER CABLING FOR COMMERCIAL APPLICATIONS

#### TIA 568A

Compliant  
Installation

## BOOK 4

### FIBER OPTIC INSTALLATION COMPLIANT WITH COMMERCIAL BUILDING WIRING STANDARDS

#### TIA 568-A

# LEVITON TELCOM:



## THE ONE SOURCE FOR ALL YOUR VOICE & DATA WIRING NEEDS.

*Leviton Telcom is a business unit of Leviton Manufacturing Co. Inc., a world-leading manufacturer of wiring devices since 1906. At Leviton Telcom, **EXCELLENCE IN CONNECTIVITY AND SUPPORT** is the underlying business philosophy that gives you extra value from every product and service we offer. Through product design, selection, performance, installation, and application information, our commitment to excellence makes us your best single resource for all of your copper and fiber wiring interfaces from the most basic telephone systems to high-end data networks.*

### EXCELLENCE IN CONNECTIVITY

One of the most trusted names in the industry, Leviton Telcom stands apart as the company which believes product innovation, system design and technical assistance are equally important. Leviton is well equipped to provide product line breadth and quality for a complete system of voice and data wiring connectivity products to support a full range of applications and requirements.

- **Quality workmanship with on-site product design, manufacture, and testing.**
- **All products are tested to exceed the latest industry standards, including Category 3, Category 5 Power Sum, proposed Category 5e and proposed Category 6.**
- **Made-in-USA Products.**
- **UL Listed and CSA Certified Products.**
- **ISO 9001 Registered Company.**

### EXCELLENCE IN SUPPORT

Leviton Telcom employs an extensive network of support services for our customers. Customer Service and Sales Support provide product ordering services and supporting literature. An extensive Technical Support Department includes highly trained Registered Communications Distribution Designers (RCDDs) to answer specific questions about products, and broad application and installation questions. Leviton is also an active member of many important industry regulatory and standards bodies including TIA and BICSI to ensure performance and standards compliance.







## CERTIFIED CABLING SYSTEM PROGRAM

As the TIA cautions, the quality of workmanship during installation can make or break the performance of high-speed structured cabling systems. Leviton's Certified Cabling System Program is a strong, synergized program which coordinates, controls and assures quality for all aspects of your high-performance cabling system, including system design, installation, testing and maintenance by the most highly qualified installers in the industry. It is Leviton's guarantee that any system installed by a CCS installer will operate reliably and trouble-free.

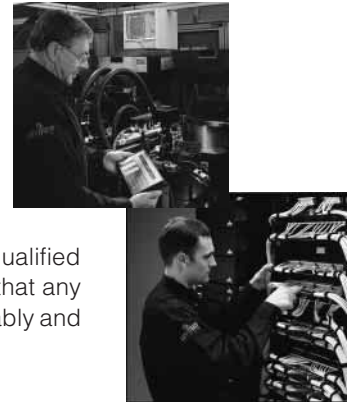

## LIFETIME WARRANTY

In league with product certification, Leviton produces the highest quality products available and backs them with one of the strongest warranties in the industry. Leviton's Lifetime Warranty on parts and performance provides you with the assurance that a Leviton CCS installed system will support any current and future application developed for TIA/EIA-568-A. It also covers your system against defects in material and workmanship for all Leviton CCS products for as long as they are installed in a certified cabling system.



***Lifetime***  
PERFORMANCE **WARRANTY**  
ON CERTIFIED SYSTEMS

# ABOUT THIS GUIDE

## PURPOSE

This document provides a basic overview of the purpose and application of industry standard EIA/TIA-568-A and -570 wiring systems, developed by the Electronic Industry Association (EIA) and the Telecommunications Industry Association (TIA) for twisted pair and fiber optic cabling.

## SCOPE

This book contains information about horizontal wiring system design, installation and administration as suggested by the following standards: Commercial Building Wiring Standard, TIA-568-A (incorporating the Telecommunications Systems Bulletins TSB-36 and TSB-40); Residential and Light Commercial Wiring Standard, TIA-570 (incorporating Standards Proposal 3490-A); Wiring Administration Standard, TIA-606; and Transmission Specifications For Field Testing of UTP Cabling Systems, TSB-67.

This document is intended only as an overview of standards-compliant installation practices, to serve as a helpful reference for horizontal wiring system designers and installers. This document does not attempt to cover backbone wiring materials or practices, or non-installation issues except where pertinent. This document is not a replacement for reading and understanding the actual standards documents to which it refers. Leviton Telecom recommends that you read and understand the standards documents before installing telecommunications wiring and devices.

## HOW TO USE THIS GUIDE

This guide is divided into four sections or “books”, allowing you to read some or all of the sections for information of interest on wiring concepts and practices, or easily consult specific sections for field reference. Leviton recommends that you initially read all of the sections, in consecutive order.

## PLEASE NOTE

This booklet contains information for use solely by professional wiring system designers and installers. While Leviton believes the information contained herein to be accurate and current as of publication, it makes no warranty of any kind, express or implied. Leviton assumes no liability or obligation of any kind, and the reader is cautioned to abide by all national and local electrical and telephone codes, rules and regulations, and to use common sense in utilizing this information.

ST® is a registered trademark of AT&T. Other trademarks are the registered trademarks of their respective owners.

**For product ordering, call Customer Service at 1-800-722-2082. For technical and application information, call 1-800-722-2082. For product information and to order literature, call 1-800-922-6229.**

**Information is accurate at the time of printing, but is subject to change at any time without notice.**

## TELECOMMUNICATIONS STANDARDS OVERVIEW

### 1.1 EIA/TIA STANDARDS CREATE A UNIVERSAL WIRING TOPOLOGY TO SUPPORT MULTIPLE APPLICATIONS

The TIA standards development committees (TR-41.8) were formed to develop standards for structured cabling systems and infrastructure. These committees consist of the major cabling system vendors, component vendors, and liaisons to applications groups.

In the past, the telecommunication industry responded to market needs with separate standards that mirrored industry application implementations. Token Ring ran on 150Ω Shielded Twisted Pair. 3270 ran on RG-62 coax. Ethernet ran on RG-58 coax. Phones were run on Quad wire or 100Ω unshielded twisted pair. And each of these applications had its own standard.

As the number of installations of each application grew, more standards were needed to address performance and compatibility between suppliers. For example, lower-cost wiring systems were added to Ethernet, Token Ring and FDDI—but each application still required a unique cabling system.

All these separate standards added up to one big headache for installers and end-users because as more network types were added, the installation and maintenance of multiple—and often incompatible—wiring systems within buildings and campuses became very difficult.

The diversity and number of available services, and the continual addition of new services, resulted in serious limitations regarding system operation, adaptability and maintenance. As a result, user demand grew for a common cabling system that would accommodate all applications. EIA/TIA-568-A was developed in response to this need by establishing a standard for a generic cabling system that can accommodate many applications.

Like many earlier application-specific standards, the EIA/TIA-568-A wiring standard and Category rating system reflect prevailing practices by a majority of the telecommunications industry. Also, in response to market demands for higher data rate applications at lower costs, the TIA defined specifications for Category 5 UTP, Extended 150Ω STP wiring systems, and Enhanced Category 5 (Category 5e) and Category 6, as well as a

standard for Residential/Light Commercial Wiring—EIA/TIA-570.

At the time of publication, several addenda to EIA/TIA-568-A were in various stages of development. One addendum sets additional requirements for Category 5 installations to insure compatibility with applications such as 1000Base-T (most installed Cat 5 systems meets these requirements). Another addendum addresses Enhanced Category 5 channel and link requirements, called Category 5e. Still another proposal seeks to define parameters for Category 6.

Because standards are still being adopted and updated, many people in the telecommunications industry are confused about which wiring systems apply to their current and anticipated applications. With so many products and applications being constantly introduced, many data system managers and specification engineers aren't even sure what equipment and applications will run on various wiring systems. It is the purpose of this publication to reduce the confusion by explaining the standards requirements in simpler terms.

#### 1.1.1 COMPLIANT PRODUCTS ALONE DON'T GUARANTEE A COMPLIANT SYSTEM

With so much emphasis on compliant components, many forget that systems will not comply or perform to the desired Category rating unless proper installation practices are followed. TIA-568-A warns, "It should be noted that meeting requirements for connector categories 3, 4, and 5 is not sufficient in itself to ensure required system performance." This statement is also applicable to the proposed Cat 5e and Cat 6 installations.

Proper installation and connector termination are critical to a network's overall performance and compliance. TIA-568-A states, "Cables used with connectors of the same Category rating will experience minimum performance degradation when properly installed." Consult the standard for these installation requirements.

#### 1.1.2 BENEFITS OF INSTALLING STANDARDIZED SYSTEMS

The TIA had several goals when writing the standard. They wanted the cabling system to be simple and easy to administer; for commercial applications, the cabling system had to accommodate all current applications up



to and including 100 Mbps. There are applications in excess of 100 Mbps that will run on existing Category 5 cable and there are even faster applications planned that are generating the requirements for higher level standards. In addition, they wanted to establish standard installation procedures and practices in order to guarantee optimal performance.

## 1.2 CATEGORY RATING SYSTEM

To simplify choosing telecommunications media for various application requirements, component performance can be ascertained by its Level or Category rating. All system components should be chosen from the same category rating to ensure proper performance.

### 1.2.1 THE LEVEL RATING SYSTEM

The Level system was developed by distributors to classify cabling system components such as wire and jacks into grades of performance. The Level system, though quite loosely defined, sparked industry demand for a single cabling system for all communications, and for better classification of product performance.

The only Levels that are currently in use are Level 1 and Level 2. These Levels are defined by UL as follows:

**Level 1** = Plain Old Telephone Service (POTS)

**Level 2** = IBM Type 3 cabling system

### 1.2.2 THE CATEGORY RATING SYSTEM FOR UTP

The original EIA/TIA-568 only defined requirements for applications up to 16 MHz. While this was sufficient for many applications such as voice, ISDN, 4 Mbps Token Ring, and 10Base-T, new applications with higher data rates were not addressed. The Category rating system was developed by the TIA in response to industry demands for higher data rate specifications on applications over unshielded twisted pair.

The Category information was released in two Technical Service Bulletins, TSB-36 and TSB-40. The TSB's recommended changes and additions to EIA/TIA-568 and added the Category rating system, replacing the old Level System. TSB-36 covered additional specifications for UTP cables. TSB-40 added specifications for connecting devices, such as jacks, cross-connect blocks, and patch panels. These TSB's have now been integrated into the main body of the EIA/TIA-568-A standard document.

The Categories characterize commercial building wiring systems for 100 $\Omega$  UTP cables as follows:

**Category 3** = 16 MHz (10 Mbps)

**Category 4** = 20 MHz (16 Mbps)

**Category 5** = 100 MHz (originally 100 Mbps, will run ATM and 1000Base-T)

#### **Proposed Addendums to EIA/TIA-568-A:**

**Category 5e** = 100 MHz (1000Base-T & faster ATM)

**Category 6** = 200 MHz (beyond 1000Base-T)

**You will notice that the Category rating system only applies to 100 $\Omega$  UTP wiring systems.** However, EIA/TIA-568-A does allow 150 $\Omega$  STP (also called Type 1) and 62.5/125  $\mu$ m multi-mode optical fiber. TSB-53, "Extended Specifications for 150-ohm STP Cables and Data Connectors," extends the 150 $\Omega$  cabling system from 20 MHz (Type 1) to 300 MHz (Type 1A). No extended operating frequency wiring systems for optical fiber are planned.

### 1.2.3 INTERPRETING COMPLIANCE AND PERFORMANCE TEST DATA

In order to determine compliance with Category specifications, cable and connecting hardware (jacks) must fulfill certain parameters as defined by EIA/TIA-568-A. For full Category compliance, jacks and cable must meet EIA/TIA-568-A electrical and mechanical specifications and transmission requirements.

Attenuation, near-end crosstalk (NEXT) and return loss are signal-degrading factors which greatly affect a system's transmission capability. The proportions of these factors determines a cable or connector's Category of compliance.

**Attenuation** is the loss of signal strength during transmission, where the received signal is lower in strength than the transmitted signal due to losses in the transmission medium (such as caused by resistance in the cable).

**NEXT** is a distortion of the incoming signal, caused by the coupling of noise from one pair of wires to another.

**Return loss** is the measure of the similarity of the impedance of a transmission line and the impedance at its termination.

When choosing a system, be sure to compare its test data against the Standards requirements for the performance you want.

## 1.3 OVERVIEW OF SPECIFICATIONS FOR LEVELS, CATEGORIES AND EMERGING STANDARDS

### 1.3.1 LEVEL 1

Level 1 is loosely defined as the minimum cabling system for analog voice service or Plain Old Telephone Service ("POTS"). In the past, this definition would have allowed a system as rudimentary as barbed wire running down a fence line to be considered "Level 1". However, today, although no actual performance requirements exist for Level 1, several minimum definitions have been developed to ensure that no harm occurs to the phone company network.

For Level 1 wiring systems, FCC Part 68 defines the minimum acceptable characteristics of wire, plugs and jacks; UL 1863 defines the minimum safety requirements for wire and jacks; and ICEA S-80-576 and Bellcore 48007 define the manufacturing requirements for cords and cables. Most commonly available Level 1 jacks and plugs will perform adequately for analog voice service, as long as they comply with FCC Part 68 requirements.

For Level 1 short-run residential single-line voice applications, or any application for that matter, **it is recommended that "quad" wire (four non-twisted wires within a cable jacket) should no longer be used unless it is already in place for single-line analog applications only. Unshielded twisted pair (UTP), four twisted pairs within a cable jacket is recommended for all new and multi-line installations, longer runs, and commercial applications in order to minimize pair-to-pair crosstalk and 60 Hz hum.**

Screw terminal or binding post termination types are typically sufficient to meet Level 1 needs. Most common insulation displacement type cross-connect blocks (such as 66 clip, 110, and others) exceed Level 1 needs. Wire-wrap and solder blocks should be avoided for maintenance reasons.

#### **Level 1 Wire Types:**

- 100Ω UTP is preferable, and required for any multi-line application.
- "Quad" wire is not recommended for data or network installations, but can function adequately in certain limited situations (i.e. single-line analog voice applications where it has already been installed).

#### **Level 1 Technical Requirements defined by:**

- FCC Part 68

- ICEA S-80-576
- Bellcore 48007

#### **Level 1 Performance Criteria:**

- None specified.

#### **Level 1 Safety Requirements defined by:**

- UL 1459 (Telephone)
- UL 1863 (Wire and Jacks)
- NEC® 1993, Article 800-4

### 1.3.2 LEVEL 2

UL defines Level 2 as the IBM Type 3 cabling system. IBM Type 3 cable, connectors and baluns were designed as a higher-grade 100 ohm UTP system capable of operating 1 Mbps Token Ring, 5250 and 3270 applications over shortened distances. The higher frequency IBM 5250 and 3270 applications will function on Type 3 cables even though the cable is only characterized to 1 MHz; impedance-matching devices are required to interface these IBM applications to the Type 3 media (see Table 1-1, page 1-9). Typical applications include voice and ISDN.

#### **Level 2 Wiring Types:**

- 100Ω UTP

#### **Level 2 Technical Requirements defined by:**

- FCC Part 68
- GA27-3773-1, IBM Cabling System Technical Interface

#### **Level 2 Safety Requirements:**

- UL 1459 (Telephone)
- UL 1863 (Wire and Jacks)
- NEC 1993, Article 800-4

### 1.3.3 CATEGORY 3

Category 3 is characterized to 16 MHz, to support applications up to 10 Mbps.

Typical applications are: voice, ISDN, 4 Mbps Token Ring, and 10Base-T.

#### **Category 3 Wiring Types:**

- 100Ω UTP rated Category 3

#### **Category 3 Technical Specifications defined by:**

- FCC Part 68
- EIA/TIA-568-A

#### **Category 3 Safety Requirements defined by:**

- UL 1459 (Telephone)
- UL 1863 (Wire and Jacks)
- NEC 1993, Article 800-4





### 1.3.4 CATEGORY 4

Category 4 defines cabling system requirements to support 20 MHz. Typical applications are from voice to 16 Mbps Token Ring.

**Category 4 Wiring Types:**

- 100Ω UTP rated Category 4

**Category 4 Technical Specifications defined by:**

- FCC Part 68
- EIA/TIA-568-A

**Category 4 Safety Requirements:**

- UL 1459 (Telephone)
- UL 1863 (Wire and Jacks)
- NEC 1993, Article 800-4

### 1.3.5 CATEGORY 5

Category 5 is a further extension of the EIA/TIA-568-A cabling system to 100 MHz. Originally, typical applications ranged from voice to 100 Mbps, and TP-PMD; with the addition of Draft Addendum 4 to the 568-A standard, additional requirements were proposed for a minimally compliant Category 5 channel. They were intended to further characterize the existing cabling plant. Although these are new specifications, the existing worst-case two-connector (interconnect) topologies compliant with TIA/EIA-568-A are expected to meet these requirements. Other topologies are supported as long as they meet the ELFEXT and Return Loss requirements of this document.

**Category 5 Wiring Types:**

- 100Ω UTP rated Category 5

**Category 5 Technical Specifications which apply to Category 5:**

- FCC Part 68
- EIA/TIA-568-A

**Category 5 Safety Requirements which apply to Category 5:**

- UL 1459 (Telephone)
- UL 1863 (Wire and Jacks)
- NEC 1993, Article 800-4

### 1.3.6 CATEGORY 5E

Category 5e is another extension (Addendum 5) of the EIA/TIA-568-A cabling system to 100 MHz. As with Category 5, the existing worst-case two-connector (cross-

connect) topologies compliant with TIA/EIA-568-A are expected to meet these requirements, and other topologies are supported as long as they meet the ELFEXT and Return Loss requirements of this document. In addition, Category 5e cabling provides higher performance over a minimally compliant Category 5 channel and recognizes advances in cabling technology.

**Category 5e Wiring Types:**

- 100Ω UTP rated Category 5

**Category 5e Technical Specifications which apply to Category 5e:**

- FCC Part 68
- EIA/TIA-568-A

**Category 5e Safety Requirements which apply to Category 5e:**

- UL 1459 (Telephone)
- UL 1863 (Wire and Jacks)
- NEC 1993, Article 800-4

### 1.3.7 CATEGORY 6

At the time of printing, the standards for Category 6 were still in the proposal stage.

## 1.4 OTHER NETWORK APPLICATIONS

### 1.4.1 150Ω STP WIRING SYSTEMS

IBM has changed cabling systems with every new computer system. First there was the 3270 system based on 92 ohm RG-62U coax. Then with System 36 computers came Twinax. Now Token Ring has emerged as practically the LAN of choice for IBM.

Type 1 is the initial 150 ohm STP cable and connector for Token Ring. Initially developed for 1 Mbps Token Ring, IBM extended the frequency characterization to 20 MHz for 4 Mbps, and 16 Mbps Token Ring.

Type 1A is a Type 1 system extended to 300 MHz. Most installed Type 1 cable will comply with the extended cable characteristics. But the telecommunications outlet and the telecommunications closet hub must be upgraded to Type 1A components.

Proposed applications for Type 1A are Token Ring, FDDI over STP, 155 Mbps ATM, and broadband video.

**Type 1 150Ω STP Wiring System Specifications:**

- Defined by EIA/TIA-568-A.

### Type 1A 150Ω STP Wiring System Specifications:

- Defined by EIA/TIA-568-A.

#### 1.4.2 100VG-ANYLAN

100VG-ANYLAN is now an approved standard which was proposed by Hewlett-Packard and AT&T Microsystems to the IEEE 802.12 committee. (The name is based on 100 Mbps, Voice Grade cable; and called 'ANYLAN' for its ability to support both Ethernet and token ring.)

The 100VG-ANYLAN protocol is for a 100 Mbps half duplex transmission which allows 100 Mbps on a four-pair Category 3 cabling system, but is *not* based on the 802.12 Ethernet CSMA/CD protocol (Carrier Sense Multiple Access with Collision Detection). 100VG-ANYLAN was approved in June 1995.

#### 1.4.3 100BASE-T ('FAST ETHERNET')

The IEEE 802.3 committee has also approved this standard for a 100 Mbps full duplex Ethernet application on Category 5 and possible TP-PMD-style wiring systems. This protocol goes by the name 100Base-T (meaning, 'based on 100 mbps, TP-PMD wiring').

There are three variations: 100Base-T4 for Category 3, 4 and 5; 100Base-TX specifically for Category 5 applications; and 100Base-FX for fiber. Note that backbone cable distances for Category rated UTP are restrictive—for example, if Category 5 cable is used for a 100Base-T backbone, it cannot exceed 5 meters.

#### 1.4.4 GIGABIT ETHERNET ('1000BASE-X')

The subsequent IEEE 802.3Z committee is currently working on a draft for gigabit Ethernet applications to run on fiber optic cabling. It specifies operation for three variations of micron fiber to achieve 1000Base-LX applications as follows: 62.5 micron fiber over 550 m cable; 50 micron fiber over 550 m cable; 10 micron fiber over 3000 m cable. It also specifies two variations to achieve performance of 1000Base-SX as follows: 62.5 micron fiber over 260 m cable; and 50 micron fiber over 525 m cable.

#### 1.4.5 1000BASE-T

The IEEE 802.3ab committee is also currently working on a draft for 1000Base-T applications expected to run on 100 meters of Category 5 cabling. This standard is not expected in final form before June, 1999. It will require minimal ELFEXT and return loss requirements not previously specified in EIA/TIA568-A.

#### 1.4.6 ATM

When first introduced, ATM (Asynchronous Transfer Mode) was a proposed application for a copper network capable of 155 and 622 Mbps). Since then, low-speed ATM transmission specifications have also been proposed: IBM recommends a 25 Mbps transmission, and Hewlett-Packard Co. and AT&T recommends a 51 Mbps transmission specification.

The ATM proposals are being developed by a forum of over 120 application suppliers. Physical specifications for ATM links have been defined (but not yet released) in a document called AF-PHY-0015.000. Link performance specs for UTP are listed in paragraph 5.1.1; but basically, ATM applications must meet all requirements for Category 5 as specified by TIA-568-A.

### 1.5 OTHER IMPORTANT INFORMATION

As new standards are still being introduced, there are many issues which can be easily misunderstood—and can result in not getting the system performance that is expected.

#### 1.5.1 THE DIFFERENCE BETWEEN MEGAHERTZ AND MEGABITS

The terms Megabits per second (Mbps or Mb/s) and Megahertz (MHz) are sometimes confused.

Megahertz (MHz) refers to the upper frequency band on the characterization of a cabling system.

Megabits per second (Mbps) refers to the rate that digital bits are sent between two pieces of equipment for a specific application.

#### 1.5.2 TIA-568-A IS A DOCUMENT; T568A IS A JACK WIRING PATTERN.

What a difference two letters and hyphens can make—at a glance these terms look so much alike it's easy to see how people can confuse them. But it's an important distinction. TIA-568-A is the Commercial Building Wiring Standard; T568A is one of two jack wiring patterns which comply with that standard (the other pattern is called T568B). For more information on wiring patterns, see page 2-9, Figure 2-9.



## IMPORTANT SAFETY AND INSTALLATION INFORMATION FOR ALL TELECOMMUNICATIONS APPLICATIONS

There are special safety considerations with telephone wiring that may be unknown by workers new to this field. The following hints and guidelines should be followed closely to help avoid safety hazards, and ensure trouble-free installations and high-quality telephone service.

This publication cannot, however, cover every aspect of safe installation and connection of telephone wiring. The contractor must follow local code requirements, including Article 800 of the National Electrical Code, and all rules or suggestions of the local telephone company and/or governmental and other regulatory agencies.



**HIGH VOLTAGE SAFETY TEST: EXPERIENCED ELECTRICIANS, AT FIRST CONTACT, ALWAYS ASSUME THAT HAZARDOUS VOLTAGES MAY EXIST IN ANY WIRING SYSTEM.**



**A SAFETY CHECK, USING A KNOWN, RELIABLE VOLTAGE MEASUREMENT OR DETECTION DEVICE, SHOULD BE MADE IMMEDIATELY BEFORE WORK IS STARTED AND WHENEVER WORK IS RESUMED ON ANY JOB.**



### Heart Pacemakers

Never attempt repair, installation, or modification of telephone equipment or wiring systems if you wear a pacemaker. Pacemakers can be disrupted by telephone-circuit voltages and ringing-cycle frequencies.



### Lightning and High-Voltage Danger

Most electrical injuries involving telephone wiring result from sudden, unexpected high voltages on normally low-voltage wiring. Installers may relax their normal care when handling telephone wire because it is a low-voltage system. However, telephone wiring can carry hazardous high voltages under certain unsafe conditions.

Never install or connect telephone wiring during electrical storms. Improperly protected telephone wiring can carry a fatal lightning surge for many miles.

Lightning exposure can also be a danger to telephone users. Therefore, jacks should never be installed in a position that would allow telephone use by a person while in a bathtub, hot tub, or swimming pool.

All outside wiring must be equipped with properly grounded and listed signal circuit protectors. These protectors must be installed in compliance with the requirements of the local telephone company and applicable codes. Do not remove or modify protectors or the grounding wire placed by the telephone company. Connections to telephone company independent grounding systems can be made only with the approval of the local telephone company.

Do not run open wiring between structures where it may be exposed to lightning without proper protection. Avoid wiring in or near damp locations.



### Wire Separations

Telephone wiring systems must be installed to minimize the possibility of accidental contact

with hazardous power and lighting wiring. Never place telephone wiring near bare power wires or lightning rods, antennas, transformers, steam or hot water pipes, or heating ducts. Never place telephone wire in any conduit, box, channel, duct, or other enclosure containing power or lighting circuits of any type. Always provide adequate separation of telephone wiring and other electrical wiring according to code.

When in doubt about separation distances, the "Rule of Sixes" can be used. This rule requires six feet of separation between telephone wiring and open high-voltage wiring, lightning grounding wire or grounding rods. It requires six inches of separation from all other high-voltage wiring unless in conduit.



### Avoiding Shocks

Fifty (50) to sixty (60) volts DC is normally present on an idle tip-and-ring pair. Ninety (90) volt AC ringing current can deliver a very uncomfortable shock under certain circumstances. Consequently, always use insulated tools and avoid all contact with bare terminals and grounded surfaces.

To avoid being shocked, always disconnect the dialtone service from the premise wiring while working. If you cannot disconnect, take the telephone handset (receiver) off hook. The DC level will drop and normally no AC ringing current will be delivered. (Be sure to replace the handset when work is completed.)

### Metallic Surfaces

Special caution is required when running telephone wire on or near metallic siding. Always check for stray voltages present on any metallic surfaces.

### Cutting and Drilling

Always observe trade safety rules for concealed wiring. Be extremely careful not to cut through or drill into concealed wiring or pipes. Make a small inspection opening before cutting or drilling.



### Splicing

Common wire-splicing techniques may cause the wire to break and result in poor circuit integrity. This can cause interference in the form of static and noise on the line.

### Clean Contacts

Dust or dirt can cause special problems on telephone wiring contacts. Be sure all contacts are clean and that all parts are installed correctly to protect them from dust and dirt.

## RESIDENTIAL AND LIGHT COMMERCIAL INSTALLATION PRACTICES (TIA-570 COMPLIANCE)

This section covers installations on residential and light commercial premises, which are defined as having four lines or less. The governing standard for such installations is TIA-570. This section does not address multi-family premises. For information on these types of installation, please consult the TIA-570 standard. Note that at the time of this printing, TIA-570 is being revised. However, although new applications or classes of service may be defined in future revisions, guidelines for proper structured cabling installation remain the same.

### 2.1 TELECOMMUNICATIONS WIRING OVERVIEW

It used to be that only employees of the telephone company ('telco' or 'carrier') could install jacks in a premise, using standard plugs and telephone-company-provided jacks. This changed in the mid-1980's when the Federal Communications Commission (FCC) issued wiring Docket 88-57, allowing customers/installers to connect to a carrier's jack or wiring.

The following text describes, in simplified form, the basic two-wire tip and ring circuit with metallic continuity to the telco Central Office (CO). There are many configurations that operate quite differently from the example shown. Party line and nonstandard services often require telco installation and repair only.

### 2.1.1 BASIC TELECOMMUNICATIONS CIRCUIT

A telco Central Office (CO) provides dialtone to a premise (telephony term for the space occupied by a customer or user in a building). Each premises "line appearance" for dialtone is usually connected to the serving CO with a dedicated pair of wires. This dedicated pair (conductors serving only the customer) is called *CO tip and ring*. (Figure 2-1.)

In the telecommunications circuit, when telephone sets are not in use (handset is "on hook"), there is normally 48 volts DC across tip and ring. This potential, called "CO battery", is highly filtered Direct Current supplied by power sources in the serving central office. When a telephone set goes *off hook* (i.e., the handset is picked up to place or answer a call), a 600-900Ω load is placed across the CO loop. This resistance load reduces the CO battery to 6-12 volts DC, which is called "talk battery." Normal loop current (off hook) is 20-90 milliamps, depending on the distance from the CO, resistance of the loop, and the number and electronic characteristics of the connected phone sets.

Calling signals are sent (numbers dialed) to the CO to place calls by one of two methods. A rotary dial, in series with the loop, makes and breaks the loop current through a contractor at a governed rate. These pulses are translated by the CO equipment to route the call. Tone dialing uses audio signals instead of pulses to transmit digits to the CO. The tone pad draws operating current from the talk battery to operate an internal tone generator

FIG. 2-1. Basic Telecommunications Circuit.

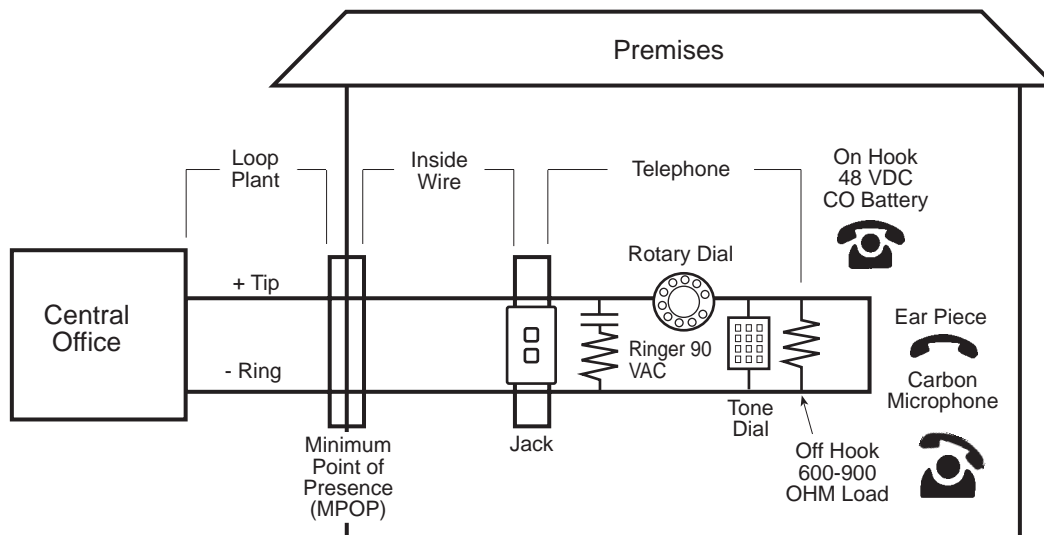
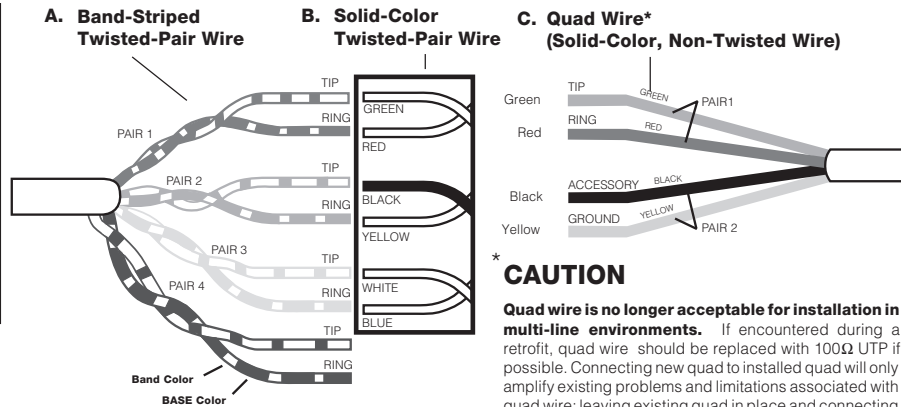



**FIG. 2-2.** Residential Telephone Wire - TIA Color Codes.

Standard 4-Pair UTP Color Codes		
PAIR 1	T	White/Blue
	R	Blue/White
PAIR 2	T	White/Orange
	R	Orange/White
PAIR 3	T	White/Green
	R	Green/White
PAIR 4	T	White/Brown
	R	Brown/White

NOTE: For 6-wire jacks use pair 1, 2 & 3 color codes. For 4-wire jacks, use pair 1 & 2 color codes.



**\* CAUTION**

**Quad wire is no longer acceptable for installation in multi-line environments.** If encountered during a retrofit, quad wire should be replaced with 100Ω UTP if possible. Connecting new quad to installed quad will only amplify existing problems and limitations associated with quad wire; leaving existing quad in place and connecting 100Ω UTP to it may also be ineffective, as the quad wire may negate the desired effect of the UTP.

For additional or commercial installation color codes see Table 3-1, page 3-7.

and amplifier that places the precise audio tones on the CO tip and ring. These tones are called DTMF (dual-tone, multi-frequency) signals. Tones are detected and processed by the CO to set up and route the call.

Incoming ringing is delivered to the premises by pulses of 90 VAC at 20-30 Hz sent down the pair from the CO. A capacitor keeps the ringer from operating except when AC ringing is present on the pair.

Note: Some telcos are installing equipment at party line residence locations to electronically convert special party line circuits to standard straight-line wiring methods. This simplifies changes and additions for customer-owned portions of the wiring system within the premises. Be sure to check with the telco on local rules and requirements.

**2.1.2 TELEPHONE WIRE**

Telephone wire carries both voice and data modulation, creating special design requirements. In order to handle these requirements, telephone wire has the following distinct characteristics:

- 1) It is normally 22 or 24 AWG;
- 2) It is always described and connected in pairs;
- 3) The two wires in each pair must be twisted together to preserve signal quality.

**2.1.2.1 The Importance of Maintaining Polarity**

Since telephone systems provide all dialing and voice functions on the polarized tip-and-ring pair with direct

current, polarity must be maintained within each pair. And the individual tip-and-ring conductors must be isolated from other tip-and-ring conductors.

**2.1.2.2 The "Pair" Concept**

Unlike electrical wiring, a telecommunications circuit requires a dedicated pair of wires. Each pair consists of a tip (+) wire and a ring (-) wire. These terms designate how each wire functions in connecting the telephone set with the telephone network.

Most residential systems will require more than a single pair to each telephone location where business lines, faxes, or modems may be in use. Future wiring changes are easier and faster if the multiple pair concept is maintained throughout the installation.

**2.1.2.3 The Reason for Twisted Pairs**

Twisted pair copper wiring is the most prevalent telecommunications media. It is relatively inexpensive, and, when installed correctly, capable of very good performance. Each pair is twisted together to prevent interference (i.e., induction and "crosstalk") from other pairs in the same cable bundle, and from outside sources like power circuits and motors.

Many newer telephones and sophisticated telephone systems will not work properly unless connected to unshielded twisted-pair (UTP) wire. Jacketed, four twisted-pair, color-coded telephone wire is recommended for all inside residential wiring (Figure 2-2).

Quad wire (four-wire, non-twisted telephone station wire) may be encountered in installations that are being expanded or changed, but it is no longer acceptable for multi-line installations. Quad wire can cause noise to be coupled onto the line. This is unacceptable, especially if multi-line use is expected to be required (which is very likely these days). **Any new telephone wire installed should be twisted-pair. If interference already exists on the wires of an installation that is being expanded or changed, it may be necessary to remove any existing quad wire, and replace it with UTP.**

## 2.1.3 TELEPHONE WIRE COLOR CODE

Many twisted pairs can be contained in a telephone cable. These cables are terminated at many different points in a telephone wiring system. Therefore, strict adherence to the color code for each connection is essential to eliminate confusion and wasted time trying to sort out nonstandard wiring.

Two color-coding systems are used to maintain separation of pairs and to indicate polarity. Both solid-color and band-striped codes are in general use.

### 2.1.3.1 Solid-color twisted pair marking

Solid-color marking for inside wiring provides distinct, single-color identification of each wire.

**Pair #1:** Green/Red (tip/ring). **Pair #2:** Black/Yellow (tip/ring). **Pair #3:** White/Blue (tip/ring). (Figure 2-2B.)

### 2.1.3.2 Band-striped twisted pair marking

The other standard telephone color-code system identifies wire with a base color of the insulation, and

a smaller band of color repeated along its length. Within each pair there is one wire that is mostly the base color, with small swatches of the band color; this is the tip wire for that pair. The other wire in the pair is mostly the band color of the first wire with small swatches of the base color; this is the ring wire for that pair (see Figure 2-2A).

Standard four-pair band-striped telephone wiring uses only five colors in distinctive combination (Figure 2-2). The color combination, coupled with the positioning of each color as either the base or the band, identifies the pair number, the tip wire, and the ring wire within the pair. (For 25-pair color coding, please see Appendix C in the back of this guide.)

**Pair #1: White/Blue.**

The tip lead is mostly white (base) with blue bands.

The ring lead of this pair is mostly blue, with white swatches.

**Pair #2: White/Orange.**

Tip mostly white, ring mostly orange.

**Pair #3: White/Green.**

Tip mostly white, ring mostly green.

**Pair #4: White/Brown.**

Tip mostly white, ring mostly brown.

The rate of twist is usually from two to six inches counterclockwise, and may be as tight as one twist in less than half an inch. The tighter the twist, the less likely it will be distorted during installation, and the greater the immunity from interference. (See Book 3, Section 3.2.3.1 for maximum allowable untwisting for each category.) *While the specification for the rate of twist varies with the anticipated data rate carried by the installation, always untwist the least amount of cable necessary to make a connection.*

In a given cable, each pair will have twisting at a different twist rate from other pairs in the same cable (bundle). This is necessary for the same reasons that twisting itself is necessary. A given cable (cable bundle) is thus a manufactured unit with a given number of pairs, not just a random group of pairs bound together in a protective sheath.



**CAUTION: QUAD WIRE IS NO LONGER RECOMMENDED FOR USE IN ANY MULTI-LINE APPLICATION.**

Quad's lack of pair twisting makes it susceptible to interference and should only be used in non-telecommunications applications such as doorbells, HVAC and perhaps security systems.

**Current standards require Category 3 UTP as the minimum grade of cable for all twisted pair residential applications,** to ensure minimum performance for home computer use and compatibility with future multimedia services. Consider installing at least Category 5.

## 2.2 GENERAL TELECOMMUNICATIONS WIRING INSTALLATION PRACTICES

It is important that the premises telecommunications wiring system be installed using the proper wiring devices and techniques. This section describes the generally

preferred methods for roughing-in and installing telecommunications wiring and information outlets.

**NOTE: The UTP installation practices in this section are basic procedures and considerations for Residential applications only. Additional UTP installation requirements for Commercial premises in compliance with TIA-568-A and Category requirements are in Book 3 of this Guide.**

## 2.2.1 TIA PREFERRED WIRING METHOD FOR RESIDENTIAL/LIGHT COMMERCIAL

The wiring method preferred by the Telecommunication Industry Association (TIA) for residential/light commercial premises is the star method (also called home run).

With star wiring, each telecommunications outlet is directly wired to the distribution device. The distribution device is a common point for terminating all distribution wire runs and for originating all inside wire runs. It provides for the connection of inside wire to distribution wire, and may also provide for the connection of control equipment in system applications. (“Inside” wire refers to four-pair UTP wire.)

The star wiring method offers many advantages. For example, if a wire is damaged during construction, the loss is confined only to that run instead of all jacks beyond the damage. Since the damaged run can be isolated, the fault can be easily located with test equipment. And if the customer wants to add additional telephone lines, the connections can be easily made at the distribution device, so there is no need to remove, rewire, and replace jacks.

Fixed devices such as intercoms, security systems, sensors and smoke detectors may be wired in a star, loop or daisy chain configuration.

The EIA/TIA standards are designed to be generic to allow multiple vendors’ components of the same Category rating to be used successfully in the same system. As another benefit, a TIA standard-compliant cabling system can accommodate future equipment and service changes to simplify ongoing maintenance and relocation.

## 2.2.2 ROUGHING-IN CORRECTLY

The following are general rules for running cable, whether residential, light industrial or commercial:

- **Always make a quick check for shorts, opens, and ground when the rough-in is completed.**

Lightweight telephone wiring is much easier to damage than other cable types. The jacket can be caught on sharp edges or nail points and inside conductors grounded, shorted, or broken. It will take just a few minutes to ensure that no connections were forgotten and that no wiring was damaged as it was pulled in or secured during rough-in.

- **Do not splice wires on the cable runs.** Pull a new wire if things go wrong.
- **Do not exert more than 25 pounds of pulling tension on 4-pair cables.** Larger capacity cables should be pulled as per the manufacturer’s directions.
- **Do not run cables in parallel with power wiring.** See Table 2-1 for minimum separation of telecommunications cable from interference sources.
- **Do not bend cable sharply** or nick the protective sheath over the insulated wires.
- **Maintain polarity** (i.e., carefully match wire colors) of the Tip (+) and Ring (-) pairs from the demarcation point to the outlets. Polarity reversal causes problems with some telephones and most data devices.
- **To provide compatibility with two-line telephones, wire up the two inner pairs of a jack.** If using the recommended 4-pair jack with industry standard wiring, this is automatically included.
- **Use plastic non-metallic-type staples** to support wire, and leave the wire loose inside the staples—do not drive staples all the way in. Driving staples in tightly may crimp wire and damage the insulation or wire, impairing its ability to carry voice/data.
- **If conduit is installed, always leave a pull cord in** to facilitate running new wire.
- **Never run power in the same conduit with telecommunications cable.** Only low-voltage monitor and control lines may share conduit with telecommunications.
- **Avoid undercarpet runs if possible,** as they are inherently more susceptible to damage, particularly in residences. If they must be installed, follow the manufacturer’s directions carefully, and remember that only one transition from one type of cabling to another is standard in a single room. Avoid installing undercarpet runs in damp areas. Note that undercarpet power cables are not allowed in residential installations.
- **Where possible, use inner walls for runs to avoid conflict with firebreaks and insulation.** Inner-wall wiring also makes it a lot easier to replace wires if necessary, or to add wires. Nonetheless, wiring

through external walls is not always avoidable, so installation handling should be the same as for electrical wire.

- **Do not run telecommunications wire parallel to power wiring without adequate separation. Instead, cross them at 90° angles, and do not share bore holes with power wires** (see Fig. 2-3 & Table 2-1).
- **Keep wire away from sources of heat**, like hot water pipes and heater ducts, and glass walls subject to direct sunlight.
- **Avoid running external wires**—they are not desirable, both for appearance and safety reasons. Wires on the outside of a building may be allowed under local code for additions, but should be avoided for initial installations.
- **Leave 18 inches of spare wire at outlets and connection points** for connections and changes.

**TABLE 2-1.** Minimum Separations Between Residential & Light Commercial Telecommunications Wiring and Other Wiring.

Purpose	Type of Wire Involved	Minimum Separation
Electric Supply	Bare light or power of any voltage.	5 feet
	Open wiring not over 300 volts.	2 inches
	Wires in conduit, or in armored or non-metallic sheath cable/power ground wires.	None
Radio & TV	Antenna lead & ground wires without grounded shield.	4 inches
Signal/Control Wire	Open wiring not over 300 volts.	None
CATV Cables	Community television systems coaxial cables with grounded shield.	None
Telephone Service Drop Wire	Aerial or buried.	2 inches
Sign	Neon signs and associated wiring from transformer.	6 inches
Fluorescent Lighting	Fluorescent lighting wire.	5 inches
Lightning System	Lightning rods and wires.	6 feet

**FIG. 2-3.** Interstud Wiring.

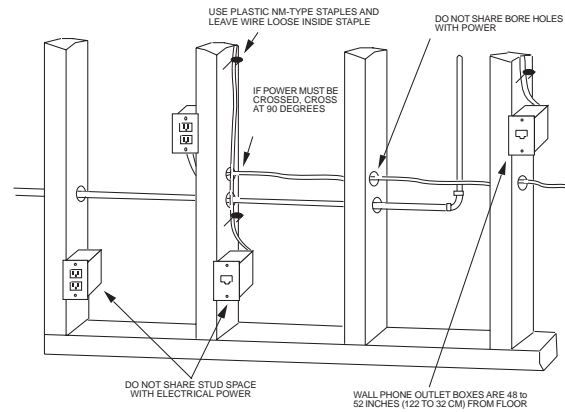

- **Firestopping, bonding, and grounding must be performed according to fire, building, and electrical codes that apply.** This document does not cover those issues, but a resource list for such documents is provided in Appendix E of this Guide.

Regardless of the installation type, proper wiring requires good planning and careful work to avoid damaging cables and to make good connections.

### 2.2.3 RESIDENTIAL TELECOMMUNICATIONS OUTLETS

For residential applications, the 8-position jack, wired to T568A pin/pair assignment is recommended. It must accept 6-position plugs.

- **When installing outlet boxes on wooden studs, it is important to maintain proper separation of communications and power cables** (see Table 2-1). These two types of cables should not share drill holes or stud spaces. Desk telephone jacks should be located at the same distance from the floor as electrical outlets. (See Figure 2-3.)
- **Any data outlet should, at minimum, be served by one 100Ω UTP cable in addition to any voice cabling at the same outlet.**
- **Consider the potential layout of furniture in a room when positioning outlets.** The standard for line cords is 10 feet or less and that should be taken into account. In offices it is desirable to place outlets on opposing walls in the event furniture is rearranged.

BOOK

# 2

RESIDENTIAL AND LIGHT COMMERCIAL APPLICATIONS

EIA/TIA 570

Compliant Installation



### 2.2.3.1 Recommended Cabling Systems

Standards Proposal 3490-A is a proposed modification of TIA-570. It proposes different grades of residential cabling depending on the services supported within a residence. Typical services available cover a broad range including telephone, data, video, multi-media, home automation systems, environmental control, security, audio, television, sensors, alarms and paging.

**Grade 1** Cabling supports telephone, CATV and data applications. Minimum cable requirements are a four-pair 100 ohm UTP that meet or exceed Category 3 transmission requirements and 75 ohm coaxial cables.

**Grade 2** Cabling supports all that Grade 1 supports, as well as multimedia applications including fiber optic wiring. Minimum cable requirements consist of four-pair 100 ohm UTP cables that meet or exceed requirements for Category 5 cable and 75 ohm coaxial cables. Two strand 62.5/125 $\mu$ m optical fiber cable is an optional cable for Grade 2 installations.

For full compliance, jacks must be wired to the T568A or T568B pin/pair assignment, and all four pairs being terminated.

### 2.2.3.2 Recommendations for Distribution Device Areas

The size and spacing of residential distribution devices is determined by the grade of service and number of outlets. (see Table 2-2). All distribution devices should either be mounted on 3/4" plywood backboard or within a recessed stud space.

Electric power at the distribution device is required by both Grades 1 and 2.

**TABLE 2-2.** Minimum Space for Distribution Device.

Number of Outlets	Grade 1	Grade 2
1 to 8	41 cm (16") wide 61 cm (24") high	81 cm (32") wide 153 cm (60") high
9 to 16	81 cm (32") wide 92 cm (36") high	81 cm (32") wide 153 cm (60") high
17 to 24	81 cm (32") wide 107 cm (42") high	92 cm (36") wide 153 cm (60") high
More than 24	81 cm (32") wide 153 cm (60") high	92 cm (36") wide 153 cm (60") high

## 2.2.4 CONNECTOR TERMINATIONS

There are two basic types of technology used for connection of individual wires to telecommunications information outlets: binding post or insulation displacement (IDC).

### 2.2.4.1 Binding Post Connections

Binding post (screw terminal) connections (Fig. 2-4) are the most common method for terminating residential wiring to an outlet. A screw and washer are used to secure the individual stripped wire leads. They are usually used where only a few terminations are necessary because they are time-consuming to install.

- **Be careful not to nick the inner copper conductors when stripping wire.** As with standard electrical screw terminal connections, copper conductors should be wrapped clockwise between two washers.
- **Be sure the wire does not get caught in the screw threads,** as it may break. It may then appear to be connected only because the insulated portion is trapped by the washers. Many "opens" appearing after device installation can be traced to broken inside copper conductors in connections that appeared sound because the plastic insulation was secured between washers. Overtightening can also break the conductor.
- **Trim off any excess exposed bare wire.** Spade lugs should be connected between the head of the screw and the first (top) washer. Binding posts are not designed to accept more than two or three wires under a single screw.

**FIG. 2-4.** Binding Post Connection.



- **Avoid sloppy device termination, which often causes wire faults such as crosses and shorts.** Stripping too much wire and failing to inspect the connections carefully can lead to these faults. Often the fault does not appear until after the plate has been secured by screws and the wad of wire in the box pushes against the rear of the device.
- **Always leave plenty of spare wire at each point** to permit remaking damaged or faulted connections later. Carefully "dress" your connections so that spare conductors will remain clear of terminated connections and will not become grounded or crossed when attaching the device or straps with screws.

- **Do not tighten binding posts with more than 7 pounds of torque** because the threads may strip and make the post useless.

### 2.2.4.2 Insulation Displacement Connectors

The insulation displacement connector (IDC) method is generally perceived to be faster and more reliable than binding post connections. The conductor is not stripped but forced into a terminal strip containing sharp inside edges that pierce the insulation and make a solid electrical and mechanical connection. The wire is held tightly between two metal contacts, forming a gas-tight seal. Most insulation displacement systems require special tools for punch-down (see Fig. 2-5).

A gas-tight IDC termination eliminates the chance for bi-

**FIG. 2-5.** Punched-Down IDC Connections (shown on a 66-clip block).

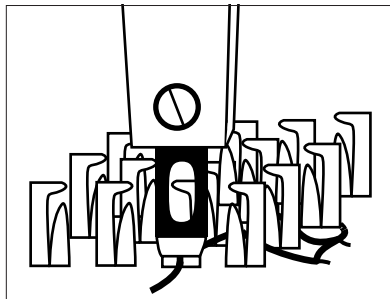

metal corrosion which exists with screw terminal devices where a bare copper conductor and a screw of a different material (usually zinc plated) are connected in the presence of oxygen from the surrounding air.

There are several styles of IDC's, each using different methods of operation. The most common IDC types are 66 clip and 110. There are also several other types on the market, but regardless of type, all use similar methods of insulation displacement connection using various punchdown tools. The wire is forced between two surfaces (usually with a special punchdown tool) and the insulation is pierced, cut or displaced.

All IDC types are designed for relatively permanent connection; if changes have to be made, the wire must be removed and the connector cleaned of all metal and insulation material before the wire can be cut off and reinstalled. Assure that the type used is appropriate for the application in size (capacity) and rating; **IDC termination is specified for compliance with TIA-568-A Category 3, 4 or 5 (see Book 3).**

#### 2.2.4.2.1 66 Clip Connecting Blocks

These industry-standard blocks (Fig. 2-6) can be used as a distribution device or in equipment rooms to connect voice and data network wiring to customer premise

**FIG. 2-6.** 66-Clip Connecting Block.



equipment. They are also used in remote and intermediate wiring closets throughout larger installations as common connecting points for nearby equipment. Some products employ IDC blocks at the station as well.

#### 2.2.4.2.2 110 Connector Blocks

**FIG. 2-7.** 110 Connecting Block.



Another form of insulation displacement connection is the 110 connector block (Fig. 2-7). These blocks can be used as a distribution device or in wiring closets and equipment rooms. Each 110 IDC unit contains double-ended insulation displacement quick clips that terminate 22-26 gauge solid wire. These clips provide gas-tight connections and are fully enclosed in non-conductive plastic to eliminate the possibility of accidental contacts or "hits" on sensitive circuits. A 110 punchdown tool is required for proper installation.

#### 2.2.4.2.3 Category-Compliant Jacks with 110 IDC Connectors

**FIG. 2-8.** 110 IDC-Terminated Jack.



These individually housed jacks (Fig. 2-8) are installed in voice and data information outlets, providing a direct termination between the station wiring and the jack contacts. Using a jack with 110-type insulation displacement connectors eliminates the need for an

intermediate block connection, and ensures solid, undisturbed terminations. IDC termination is specified for compliance with TIA-568-A.

### 2.2.5 JACKS

A jack is a receptacle for standard telephone equipment to plug into. Jacks can be wired in a variety of ways to satisfy individual requirements of a particular application. (Note: connectors for fiber optic cable are covered in Book 4.)

### 2.2.5.1 Wiring Jacks For Residential Applications

The EIA/TIA-570 standard, when revised, will recommend the use of 8-conductor jacks only. However, the use of 4-conductor and 6-conductor jacks is still widespread in residential applications. Leviton strongly recommends that at least Category 5 wiring and devices be used for all residential and light commercial telecommunications wiring. This Category of cable will allow the building occupants great future flexibility for the usage of the telecommunications wiring.

While the recommended standard is to follow the TIA wiring scheme, there are (and will continue to be) telecommunications equipment (i.e., phones, fax machines, etc.) that utilize different wiring schemes. While a T568A/B wiring pattern is recommended for current and future installations, the use of USOC codes does continue today. Information on USOC codes is provided in Appendix D should you run across them in your work.

In general, residential applications are wired with one or sometimes two jacks per room. Older, more traditional style residential jacks are wired with screw terminals, but some of the newer style modular jacks are wired with insulation displacement systems. Typically, for small jacks, a special termination tool is provided that has limited life. Be sure to follow the manufacturer's directions for termination, and use the proper tool.

**Note: For terminating a jack with IDCs, a screwdriver blade will NOT do the job properly—in fact, it will cause more problems.** Also, if things go wrong or changes need to be made, you need to remove the wire and any shreds of insulation material and re-terminate.

### 2.2.5.2 Wiring Jacks For Light Commercial Applications

Light commercial applications typically use eight-position jacks, and are wired for at least two jacks at every workstation. Commercial applications are wired this way also; see Book 3 for TIA-568-A compliant installation practices.

- **In general, all light commercial jacks should be wired to the TIA-568-A standard wiring pattern 'T568A' or 'T568B'** (unless specific circumstances dictate that other wiring schemes be used). These will accommodate both six-position USOC plugs and ISDN applications, as well as most common commercial applications. (See Fig. 2-9.)

**Note On USOC Codes:** Be aware that with regard to wiring 8-conductor jacks, there are two separate industry wiring standards often called USOC. Basically, two USOC codes have evolved: the original USOC code developed before the FCC issued a code, and the USOC code RJ61X later registered by the FCC. The only difference between the two is that the pair consisting of pins 1 and 8 is reversed. A mix-up can cause a system to work improperly, and require additional labor for troubleshooting and re-wiring.

Since the two wiring patterns are often called by the same general name 'USOC', it is important to verify the pin-outs of the required wiring configuration where a USOC code is required, and use the more specific term RJ61X where that wiring pattern is desired.

USOC (Generic)			RJ61X		
Pin Desig.	Jack Pin #	Wire Color	Pin Desig.	Jack Pin #	Wire Color
T1	5	Wht/Blue	T1	5	Wht/Blue
R1	4	Blue	R1	4	Blue
T2	3	Wht/Orange	T2	3	Wht/Orange
R2	6	Orange	R2	6	Orange
T3	2	Wht/Green	T3	2	Wht/Green
R3	7	Green	R3	7	Green
T4	8	Wht/Brown	T4	1	Wht/Brown
R4	1	Brown	R4	8	Brown

Both T568A and T568B wiring will accommodate standard telephone sets, ISDN, and most data line phones.

- **Install jacks at the same height as electrical outlets.** Wall-mount phone jacks should be 48 to 52 inches from the floor.
- **Cover unused wallboxes with a blank wall plate** to protect and mark their location.

## 2.3 GENERAL TIPS ON INSTALLING MODULAR CABLES & JACKS

- **Six-position modular cables from the wall to the telephone or other equipment are typically "frogged" or "mirror image" on each end**—and that is OK because the equipment expects that.
- **The jack (and plug) of the handset of the phone is usually smaller than the one that goes from the wall to the phone; typically a four position plug.**
- **"Tinsel" and stranded wiring is used between the wall and most phones and other devices because it is more flexible than solid wire.** Stranded wire is used for extension cords, distribution cords and patch cords.

**FIG. 2-9.** T568A and T568B Compliant Wiring Configurations

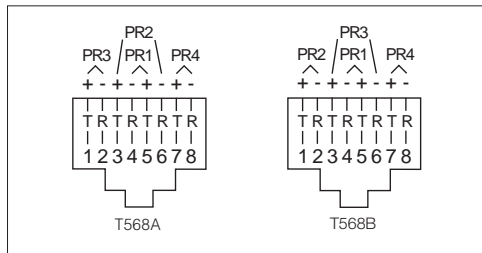

- **Wire each jack to be standard T568A or T568B unless good reason exists to do otherwise** (for example, the jack has only six conductors, or the equipment requires a different wiring scheme to operate). External adapters are preferred for odd requirements, like splitting out a line for two pieces of equipment (phone and answering machine, for example). Standard wiring is easier to troubleshoot and less likely to result in confusion later.

**IMPORTANT:** For your protection, please read and understand all installation warnings and cautions on page 1-6.

**NOTE:** Information on compliance with TIA-606, the Wiring Administration standard, can be found in Book 3.

## 2.4 GENERAL TIPS ON QUALITY INSTALLATIONS

- **Every connection degrades system performance, so use the minimum necessary.**
- **Better to provide excess capacity in terms of cable and outlets than not enough.** Later additions are costly and time consuming.
- **Wire to the highest anticipated data rate (speed) or greater—never less.**
- **Never install components of unknown/questionable origin or quality.** At the very best, the system will transmit signals to the level of its weakest component. Every element and connection is important.
- **Document all connections carefully, and keep installations neat and tidy.** This will save time and hassle when modifying or troubleshooting the system later.
- **Test everything.**



## 2.5 RESIDENTIAL WIRING DIAGRAMS

The following illustrations are provided as a basic guideline for various residential wiring systems.

Each illustration shows a simple residence with a single wiring system depicted. For each wiring system, the following topics are addressed: *cable type*, *terminations*, *wiring topology*, *connectivity* (i.e. how devices are attached to the wiring) and *other considerations*.

Of course, each installation will call for its own special wiring requirements. Use these diagrams as a starting point while planning each wiring system for a particular job.

The distribution devices mentioned for each system are typically co-located in a garage or other utility area of the home. For a discussion of the size requirements for distribution device backboard, see Table 2-2. Other considerations for the distribution device location include access to electrical power, surge protection and access to electrical ground (<1.5 meters or 5 feet).

For new construction, it is recommended that cable be run in concealed pathways. Consider using conduit for cable pathways to allow for pulling additional wiring in the future. For retrofits of an existing structure, conceal the wiring in attics or crawl spaces wherever possible. For exposed retrofit cabling, enclose the cables in protective surface-mount raceway.

Finally, consider installing wire in areas such as attics, basements, bathrooms, etc. Requirements for wiring in unusual areas will be dictated by different factors for each job.

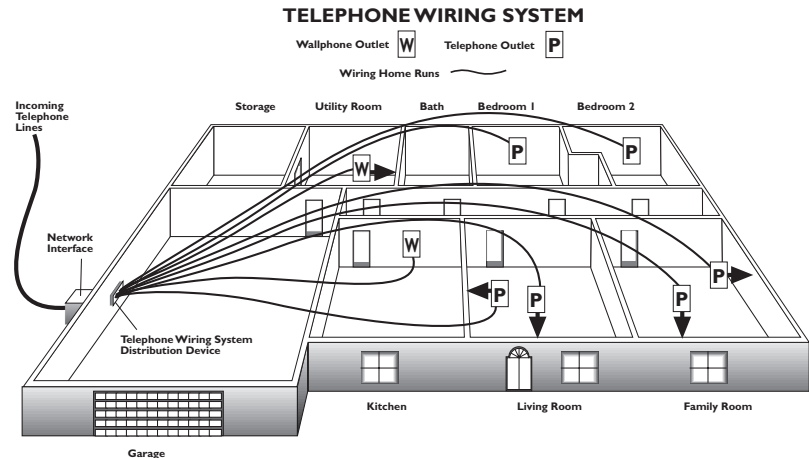

### TELEPHONE WIRING SYSTEM

**Cable Type:** 4 pair 100 Ohm UTP—Category 3 minimum, for Grade 1 installations; Category 5 for Grade 2 installations.

#### Terminations:

**Outlet End:** 8 position Category 5 jack with T568A wiring (or may use T568B). Minimum of one voice jack per outlet. Other outlets in same room must be separate home runs.

**Distribution End:** Bridged or unbridged termination modules, or punch-down block for a more versatile system.

**Topology:** Home run (star wired) from common distribution point.

**Connectivity:** Phones plug in at the outlet, incoming dial tone pairs punch down and are routed at distribution device.

**Other Considerations:** Consider flexible assignment of dial tone sources to various rooms. Consider breaking out individual pairs at outlets using external breakout box. Consider additional requirements for key telephone system, etc. Install a wall phone jack in kitchen and at least one voice outlet in each bedroom. Consider extra outlets in larger rooms, or in rooms where furniture arrangements may dictate requirements for outlets on two or more walls.

## DATA WIRING SYSTEM

**Cable Type:** 4 pair 100 Ohm UTP— Category 3 minimum for Grade 1 installations, Category 5 for Grade 2 installations.

**Terminations:**

**Outlet End:** 8 position Category 5 jack with T568A wiring (or may use T568B). Minimum of one data jack per outlet. Other outlets in same room must be separate home runs.

**Distribution End:** Unbridged module, Category 5 patch block (or Category 5 patch panel) or individual Category 5 jacks mounted in a housing, bracket or panel T568A wiring (or T568B may be used). Wiring must match the wiring at the outlet.

**Topology:** Home run to common distribution point (usually same area as telephone wiring system distribution point)

**Connectivity:** Patch cords from hub to panel/block/etc. at distribution end; patch cords from outlet to data terminal network connection (i.e. the NIC card jack).

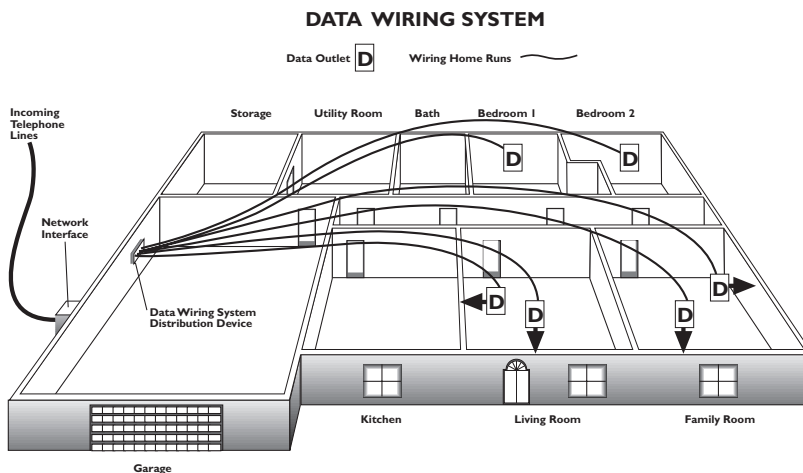

**Other Considerations:** Local Area Network data hub mounts on wall near distribution device. Install a data jack in each bedroom. Consider extra outlets in larger

rooms, in home office areas, or in rooms where furniture arrangements may dictate requirements for outlets on two or more walls.

## AUDIO/VIDEO (BASEBAND) SYSTEM WIRING

**Cable Type:** 2 or 4 conductor stranded, low-inductance audio wire per speaker—for high power applications. For low power applications, shielded, line level cables of various types for audio/video signals.

**Terminations:**

**Outlet End:** Binding posts, banana jacks, RCAs or push/insert type connectors in wallplates.

**Distribution End:** Varies depending on audio/video distribution unit.

**Topology:** Home runs from potential entertainment system locations to audio/video distribution unit. Home runs from in-wall speakers, ceiling speakers, or audio/video outlets via speaker volume controls to audio distribution unit. Audio/video wiring distribution point may be co-located with voice/data/video distribution devices, or may be near the entertainment center location, or other convenient location as a sub-system.

**Connectivity:** Jumper cables from outlets to free-standing speakers and/or patch cords and cables to audio/video components. Wires terminate directly into audio/video distribution unit at distribution end.

**Other Considerations:** The audio/video distribution unit may be an electronic device which allows flexible assignment of multiple sets of speakers to one or more audio/video sources.

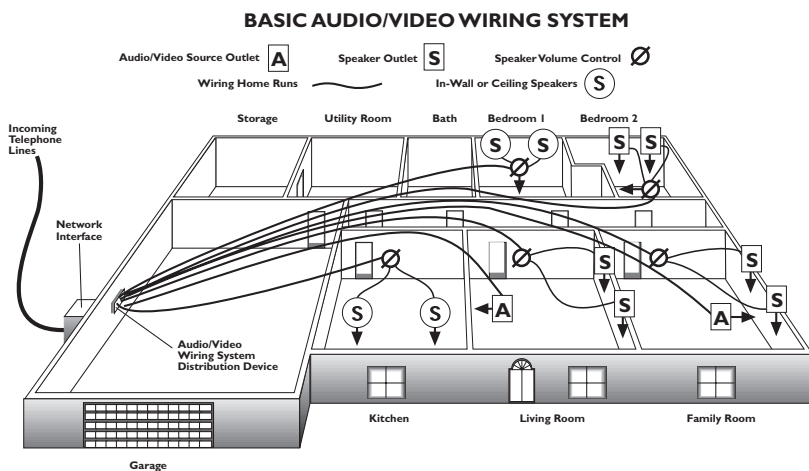

BOOK 2

RESIDENTIAL AND LIGHT COMMERCIAL APPLICATIONS

EIA/TIA 570 Compliant Installation

## VIDEO (BROADBAND) SYSTEM WIRING

**Cable Type:** RG6 Quad shield 75 Ohm coaxial cable recommended. Two runs of coax to each TV outlet location recommended (single run to front door camera location and other like locations; two runs to attic or roof for satellite). Also see "Other Considerations" below.

**Terminations:** Male F-type connector at both ends of cable. Threaded F-type fittings are recommended to reduce noise. Push-on type F-fittings are not recommended (except special high-quality push-ons.)

**Outlet End:** Attached to the rear side of the outlet (which contains a female-female F-type coupler).

**Distribution End:** Male F-type Connector.

**Topology:** Home run to common distribution point. This distribution point may be same area as voice/data wiring system distribution point or may be the entertainment center location (home theater room or family room, etc.)

**Connectivity:** At outlet end, coaxial 75 ohm patch cords extend from outlet to video device (TV, VCR, etc.) At distribution end, male F-type connectors plug directly into video service unit, splitters, etc.

**Other Considerations:** A video service unit, splitter(s), and/or amplifiers may be located at the video wiring system distribution point. Utilize 75 ohm termination caps at idle outlets. In lieu of RG6 coaxial cable, high-quality 100 ohm Category 5 UTP cable may be used for video distribution with suitable adaptive devices. (Coax-to-UTP

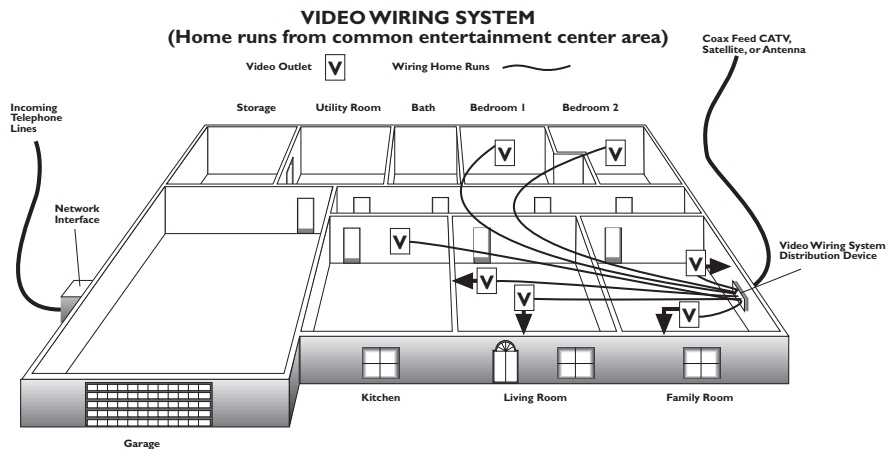
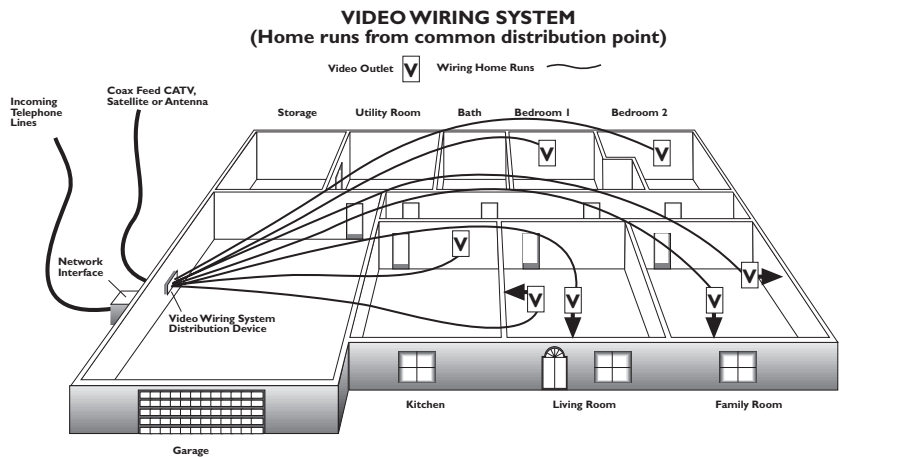

converters may be required at both ends of each cable run.) Install a video outlet in each bedroom. Consider extra outlets in larger rooms, or in rooms where video equipment may have several location options. Two runs of RG6 allow for video distribution from any video source as well as distribution to a TV at each outlet location, and RG6 coax

may become a medium for data application. Another possibility is that fiber optic cable may eventually become a medium of choice for some audio/video applications.

## FIBER OPTIC WIRING SYSTEM

**Cable Type:** 2-strand, 62.5/125mm multimode fiber optic cable.

**Terminations:** Two individual ST-type connectors (male) at each end of cable or two individual SC-type connectors (male) at each end of cable. These plug into wallplate-mounted couplings (2 STs or duplex SC) at the outlet end, and plug into panel mounted couplings at the distribution end.

**Topology:** Home run (star-wired) from common distribution point (co-located at the data distribution point).

**Connectivity:** Fiber optic patch cords at both ends.

**Other Considerations:** Fiber optic applications are not currently in common use in the residential

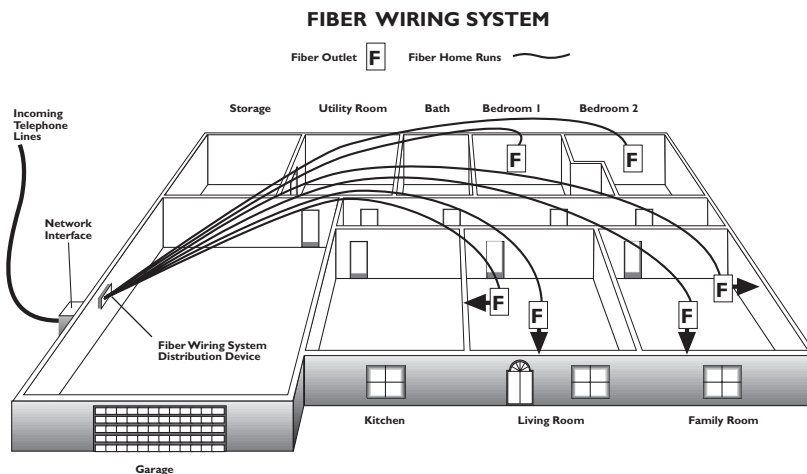

market. Cabling with fiber, however, gives the user a versatile, high-bandwidth, cabling system that may provide much future capability. As a cost savings, fiber optic cable is often left unterminated. "Service loops" may be stored behind the

outlet wallplate, and at the fiber optic wiring system distribution device. The fiber optic cable may be terminated and mounted in wallplates and at the distribution device when needed.

## BASIC SECURITY WIRING SYSTEM

**Cable Type:** Any copper communication cable

**Terminations:** Loops terminate on connections in alarm panel. Alarm panel wires to an RJ31X jack for incoming/outgoing security line connections.

**Topology:** Daisy chain security loops intercept all windows, external doors, motion detectors and smoke detectors.

**Connectivity:** Connections to sensors, detectors, etc. are permanent connections and will be dependent upon the type of device implemented.

**Other Considerations:** A touch pad, mounted in a convenient location is used to turn alarm system on/off or to set user

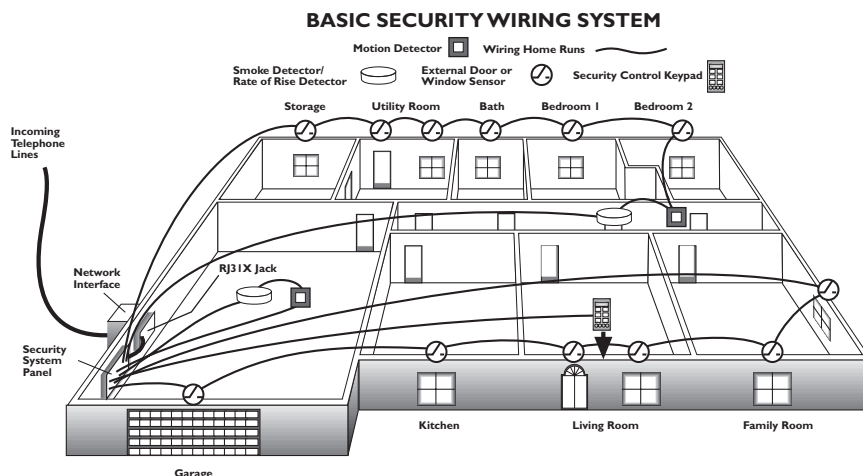

programmable options. Note: This diagram/description is provided as an example only. Please refer to security system manufacturers' recommendations for cabling requirements.





## TESTING & TROUBLESHOOTING RESIDENTIAL & LIGHT COMMERCIAL LOW VOLTAGE WIRING

Testing cable runs is relatively simple—and is much simpler if done during rough-in, prior to installing drywall. In addition, testing of runs prior to installing jacks or devices will prevent difficulty in isolating the fault. This section includes testing procedures for voice and security alarm systems.

**WARNING!** Disconnect electrical sources if at all possible before performing tests. In the event that telecommunications wiring has come in contact with power circuits, severe shock is possible. Check with a qualified electrician if you are uncertain.

**IMPORTANT:** The testing of specialized circuits for alarm systems requires special considerations. Many alarm systems depend on proper polarity to operate, and it is essential that they be tested to assure that they will function in the event of an emergency. Alarm systems also often depend on RJ31X-type USOC jacks with shorting bars to signal that the alarm system has been disconnected (tampered with).

**IMPORTANT:** Please read all cautions and warnings on page 1-6.

### 2T.1 TOOLS

Using testing and troubleshooting equipment specifically designed for telephone installation and repair will speed and simplify troubleshooting work.

Many of the tests and procedures described in this guide can be done with other less sophisticated equipment not designed for the purpose. For example, troubleshooting and wiring verification involves detection of continuity, voltage, and determination of polarity. While these tests can be accomplished using a volt-ohm meter, it is easy to misinterpret a meter reading or to forget one test during a sequence repeated many times during a complex series of tests involving many different conductors. *Experience has shown that when substitute test equipment is used, the procedures will take longer, be less reliable in finding the fault, and often will find only part of the problem.*

- **Test equipment using visual indicators (colored lights) or audible signals (beeps and tones) will simplify the job and result in fewer errors and callbacks.** When test sets and troubleshooting procedures are simplified, less experienced personnel can do more dependable testing.

#### 2T.1.1 TONE TEST SET AND INDUCTIVE PROBE

These instruments are used together to identify where particular wires are located, broken, or terminated at any point along the horizontal run. A tone test set (Fig. 2T-1) generates a tone which is audibly detected by an inductive probe (Fig. 2T-2). The probe can detect the tones without actually connecting to the wires under test, which is very useful for tracing wire/cable circuits and locating faults even through drywall or within large cable bundles. These tools provide more or fewer features depending on the manufacturer and model.

Leviton's durable, low-cost Tone Test Set (Fig. 2T-1) provides the functions needed to isolate and test wiring in virtually any type of wire application including telephone, data, CATV, HVAC systems, and security/fire alarm wiring. As a tone generator, the Tone Test Set can transmit either a continuous 1000 Hz tone or an alternating 500/1000 Hz tone for tracing pairs and locating broken pairs/cables in walls. When connected across a wire pair, the tone generator signal allows the wire to be traced and isolated by using Leviton's Inductive Speaker Probe (Fig. 2T-2). Note: When connecting to Category 5 wiring runs, the toner leads should be attached to single wires in two separate pairs. The twisting on a single Category 5 pair will attenuate the tone to the point that it cannot be detected with the speaker probe.

The Tone Test Set also provides talk battery (for establishing a communications line on an unused pair); tests for continuity; and checks for shorts and opens. In addition, it identifies tip and ring polarity, and clear, busy, and ringing lines. A light-emitting diode (LED) is used for all test indications.

FIG. 2T-1. Tone Test Set.



FIG. 2T-2. Speaker Probe.



Some tests are accomplished using the tone test set by itself, while others require the use of the inductive speaker probe. It is also possible to conduct these tests using a lineman's test set instead of the probe.

Leviton's **Inductive Speaker Probe** is designed to detect audible tones to quickly trace and identify wires or cables, without damaging the insulation. When used in conjunction with a Tone Test Set, the Speaker Probe provides the basic functions needed to trace and isolate pairs in virtually any type of wire application.

Often the installer needs to locate a pair within a cable or identify one cable from among many other cables at a terminal or behind wallboard where there is no easy access to bare connections. The Speaker Probe will allow tone to be detected without actually touching the test leads to the conductor. The probe, sometimes called a "banana" by telephone installers, will detect a strong tone several inches from the pair.

This device is a real time-saver when a large number of cables or pairs (often several hundred) could possibly contain the pair or cable you are trying to locate. These cable connections are usually terminated neatly on a large backboard full of 66 blocks. You can quickly find the pair with tone by moving the Speaker Probe along the pins of the block, if available, or by pulling each cable slightly out of the bundle of cables and touching the probe to the outer jacket, listening for tone.

Leviton's Probe has a built-in amplifier and can be used with or without a lineman's test set. A lineman's test set, in the monitor position, permits listening without aid of the amplifier portion of the probe's circuitry. There are less expensive probes on the market that have no amplifier and must be connected to a lineman's test set for use in tone locating.

Note that inductive speaker probes do not work with shielded twisted pair—the shield will block the tone, unless the toner is attached directly to an unterminated shield.

### 2T.1.2 LINEMAN'S TEST SET (BUTTSET)

Buttsets (so-called because they are used to 'butt-in' to a line) provide a means of bridging onto wire pairs for monitoring or dialing. Some models also provide information on polarity reversals and other faults.

FIG. 2T-3. Buttsets.



Though not essential, Leviton recommends a lineman's test set be used during premises wiring installation and repair. An excellent choice is a line-powered unit (one that uses no internal batteries). This type has been in use by telephone companies for many years. The test set should signal with either *rotary pulses* or *tone dialing* methods for use on any telephone circuit.

Some models have visual polarity test indicators built into the unit. These indicators show the presence of voltage and indicate proper or reversed (rolled) polarity on dial tone circuits or "dead" wiring systems under test, using a battery power source. Switches permit monitoring or talking on active pairs as well as switching in and out of the test set's network and keypad components for special tests.

### 2T.1.3 TIME DOMAIN REFLECTOMETERS (TDR'S)

Time Domain Reflectometer (TDR) instruments use radar-like principles to detect the existence and location of cable faults. The signal it sends down a suspect cable is reflected back to the test instrument, where the information is displayed for the user to interpret.

There are two important things to remember when using a TDR. First, a quality connection between the cable and the TDR is vital, as TDR signals contain high frequency characteristics that are not efficiently transmitted through poor connections or inadequate test leads. A loose or sloppy connection can cause misinterpretation and other errors.

Second, it is crucial to enter the correct VOP data (speed at which a signal travels down the particular type of cable being tested; consult the manufacturer's instructions). As with all equipment, a TDR reading will only be as accurate as the operator and the instrument settings permit it to be.

### 2T.1.4 MODULAR BREAK-OUT ADAPTERS

A modular adapter provides a convenient way to clip onto the individual pins of any 6- or 8-position modular jack or plug. Various styles exist: some break all leads of the jack out into flat conductors that alligator clips can be clipped onto, and some have a means of switching between pairs.

FIG. 2T-4. Modapt.



## 2T.2. ROUGH-IN WIRING TESTS

- **Never begin installation of telephone wiring devices on a roughed-in job until the rough-in wiring has been tested for shorts, grounds, and opens.** When starting with a verified rough-in telephone wiring system, it is possible with proper methods to detect an error in device wiring at the time the error is made. This way, if device installation is completed and a problem shows up, it is likely that the fault lies in the device termination rather than with the building wiring.
- **Failure to install proper wiring and devices before occupancy can also cause serious disagreements and builder or homeowner dissatisfaction.** These problems often arise when the occupant requests additional lines from the exchange carrier, only to be told the wiring is inadequate or "defective." Avoid these disputes by using proper materials and methods in the first place.

Some sophistication is required when troubleshooting telephone wiring systems because there are many ways problems can be created if the multi-color coded conductors are not properly matched, and devices not correctly wired. Polarity must always be observed, especially when making the transition from one color code to another. Most electrical house wiring problems show up immediately with a blown fuse or activated circuit breaker—but many telephone wiring system problems do not show up immediately, and often seem to get more complicated if repairs are attempted by untrained persons.

- **Always use proper materials to prevent trouble.** The best wire choice is UL listed, NEC Article 800 compliant, four twisted-pair jacketed inside wire. Quad wire (pairs not individually twisted) is generally not suitable because it is only designed to carry one analog voice circuit (the other two wires are for ground and accessory functions). Thus Quad wire should not be used with multiple lines, key systems, PBX systems, digital phone sets, or data applications.
- **Perform the following tests for each pair, after having made sure that the system is not connected to the network** ("pull the plug" at the demarcation point first) or, more accurately, do not connect to the network prior to completely installing and testing all components.

- **In commercial applications, test horizontal runs prior to cross-connecting at the telecommunications closet, if one is present.**



**WARNING: Hazard of Electric Shock.** These tests are not intended for use on energized wiring or circuits. To avoid electric shock, disconnect all sources of electric current before testing. If you are unfamiliar with electrical wiring, consult a qualified electrician or other professional. Check local codes or other requirements before working on electrical or communications wiring circuits.

### 2T.2.1 BASIC TESTING BEFORE TRIM-OUT

1. Do a visual inspection of wire color matching to assure that the right access line is assigned to the right set of pairs, and that Tip (+) and Ring (-) are assigned to the proper pins.
2. Next, test each pair for a) continuity, b) shorts to ground, c) shorts to other pairs ("crosses") d) reversed polarity ("roll"). See Fig. 2T-5.

See section 3T for testing Category 5 wire.

### 2T.2.2 USING A BATTERY AND VOLT-OHM METER (RESIDENTIAL):

1. Find a reliable ground connection, and check each lead at each outlet for a short(s) to ground. There should be no continuity between any of the leads and earth ground.
2. Assure that the network is disconnected. Then connect the battery across the Tip and Ring leads of each pair at the closest point available to the demarcation point, but not on the network side. Connect the positive side to Tip and the Negative side to Ring.
3. Go to each outlet and perform the following tests with the volt-ohm meter for each pair:
  - 3a. Verify that the polarity of each pair is correct with Tip at positive voltage and Ring at negative.
  - 3b. Verify that there is no continuity with any other pair at the outlet by checking the Tip lead against all other leads, and then the Ring lead against all other leads.

FIG. 2T-5. Common Wiring Faults.

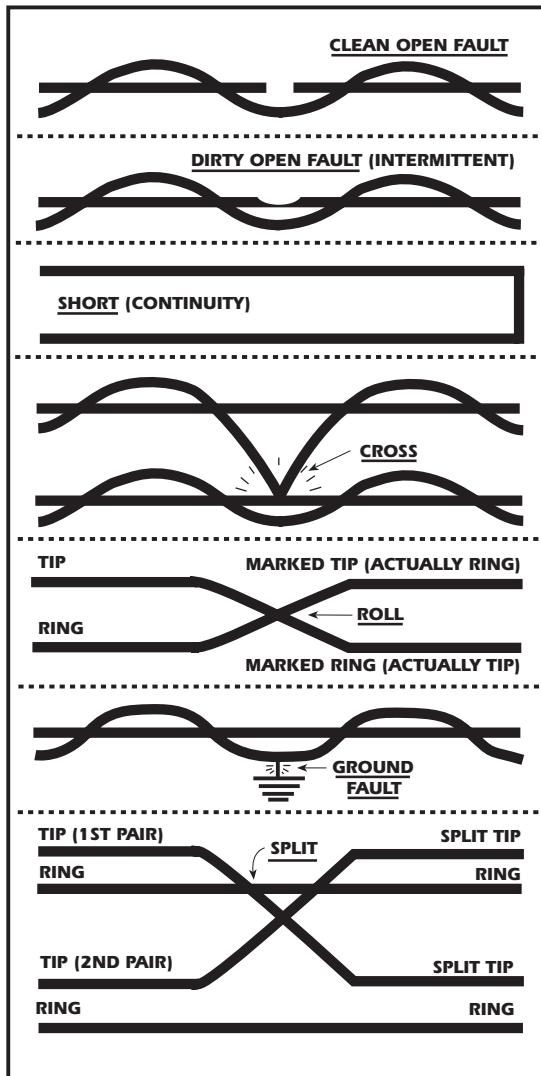

### 2T.2.3 USING A SPECIALIZED CONTINUITY TESTER

Most continuity testers provide one or more LEDs to indicate shorts, opens, and polarity. The tester provides battery voltage and if a short exists, the appropriate LED will light.

1. With the leads unterminated at either end, connect the continuity tester across the leads of each pair in succession. Test also at the outlet for continuity between the Tip lead of each pair with all other leads, and then the Ring lead with all other leads, to assure that there are no shorts to them.

2. Then short the far end by metallic means. The tester will light the appropriate LEDs to indicate proper polarity. (A toner and probe can be used to identify the proper cable, if necessary.)

*Note: This part of the test is usually not performed in high-volume commercial installations.*

### 2T.2.4 USING A TONE GENERATOR AND INDUCTIVE PROBE

These tools are used together in identifying one specific pair from others. The tone generator (toner) is attached to one end of a vacant pair which must be traced to find the location of a fault, or identified so it can be spliced for a new circuit; then the probe is used to "pick up" the tone, tracing the tone signal either along the wire or at the other end. For this test it is assumed that a continuity tester has already been used to verify continuity, polarity, and lack of shorts, yet a fault still exists.

1. Connect the toner to the leads at the outlet.
2. Take the probe to the distribution device or telecommunications closet. When the probe is held near the pair carrying tone, the tone will be quite strong. (Some lesser volume may be picked up on adjacent leads or pairs, but this is normal.)
  - The pair carrying tone can be verified by touching the tip of the probe across the leads. The tones will cease if that pair is the one carrying the tone.
  - At this point, assuming the continuity tests showed no faults, the leads are normally "punched down" in commercial applications. In residential applications they may already have been terminated at the distribution device.
3. With the toner still on at the outlet, a buttset can be connected across the pair. The impedance of the buttset provides additional information. It should pick up the tone, which should be relatively loud. If the tone is faint, an open (break) in the circuit is likely. If the tone is not heard at all with the buttset, the likely fault is a short.
4. In Commercial applications, an earth ground point is available in the telecommunications closet. Test for shorts to ground by attaching one lead of a continuity tester to that ground and running the other lead down the clips of the punchdown block (assuming the clips are accessible). In this manner the test for shorts to ground can be made after the leads are terminated.



## 2T.2.5 TESTING FOR SHORTS AND OPENS (CONTINUITY)

The continuity setting of the Tone Test Set is used to locate shorts and verify continuity (no opens). A full short is indicated with a continuously lit green LED. A resistive or dirty open condition is indicated by a dim or blinking LED.

1. Locate and identify each pair on both the outgoing and incoming roughed-in wiring.
2. Test the tester (to verify it is operational) by touching the leads together and looking at the LED for indication of a full short (steady LED).
3. Connect the test set leads to the outgoing pair (polarity does not matter here) and set the test set switch to CONT. There should be no indication of continuity until the same pair on the incoming (return feed) is shorted. Any continuity indication before shorting the return feed pair means there is a fault within the pair (or multiple grounds). Only when the return feed is shorted should there be a solid short indicated by a continuous unchanging LED like you see when shorting the leads of the tone test set.
  - If the LED is dim or blinking, there is a resistance or intermittent fault in the pair. Poor splicing or corroded splices will result in a high-resistance loop. The resistive connection or splice must be located with the probe, and corrected using a splicing tool, before connecting the circuit. Dial tone connections to a resistive loop will result in static noise, poor dialing and ringer operation, and low loop current.

## 2T.2.6 TESTING FOR CROSSES

A cross is a common fault caused by sloppy device wiring which allows a short to develop between two terminals. Usually this occurs because too much bare copper conductor is stripped and then the tail is not trimmed after connection.

Testing for crosses involves using the continuity mode of the toner to locate any electrical path from either conductor of one pair to either side of another pair. This is done as follows:

1. Attach one test set clip to the tip side of a pair (this is your fixed lead). Using the other lead, check for continuity to both sides of every other pair.
2. Next, change the fixed lead to the ring side of the same pair and repeat Step 1.
3. Repeat this sequence for each pair. If there is any continuity indication, a cross is present in the wiring.

- If a cross is located before any devices are installed, it is likely that a nail or other fastener has been driven into the roughed-in wiring. Before the wiring can be completed, a cross must be located and repaired, or isolated out of the system.

## 2T.2.7 TESTING FOR SPLITS

A split occurs when two wires of a pair are split (separated) and improperly matched with wires from another pair (for example, tip lead of pair #1 mated with ring lead of tip #2). A split will normally be located during the tests for opens and continuity previously described. Splits most often occur during splicing operations in low light, or when the splicer is tired or distracted.

1. Connect the tone test set in the TONE mode to the two wires in one pair at the end of the cable.
2. Using the speaker probe, trace the tone along the cable pairs to the splice location. Once there, identify the wires you believe are the pair of interest, and use the probe tip to short these two wires.
  - If the pair is split, the tone will remain strong when the wires are shorted.
  - If the pair is straight (not split), the tone will disappear when the wires are shorted.

Splits can also be isolated using a lineman's test set with the Tone Test Set. Refer to your lineman's test set instructions for details.

## 2T.2.8 TESTING FOR REVERSED POLARITY (ROLLS)

A rolled pair results when the tip and ring leads are reversed in connecting to the network. This may be done while splicing or installing a device. Proper polarity is essential for proper operation of some tone dials. A roll will not affect rotary dialing.

**If a true tone telephone set does not produce tone beeps when the keypad is pushed, polarity may be reversed. If changing the polarity causes the set to beep as the keys are pushed, but numbers are not dialed (i.e., dial tone stays on), then the central office is not equipped to provide touch dialing on that particular line. Some telcos charge a monthly fee to provide touch dialing capability on a line; if the fee is not paid, they may inhibit tone dialing electronically.**

If a push button set produces dial pulses when the keypad is operated, the set is not really a tone set. It may be called a "universal dialing set" but it does not signal to the central office with tones. When the keypad is operated, numbers are pulsed out just like a standard rotary dial. This type of set is easily identified by the letters "TE-R" (Terminal Equipment-Rotary) as the last three items in the FCC registration number printed on a label attached to the telephone. If the last three letters are "TE-T" (Terminal Equipment-Tone), then the set is a "true tone set" that signals the central office with tones instead of rotary dial pulses.

The Leviton Tone Test Set is equipped for polarity testing with a visual indicator. If dial tone is connected to the pair under test, the presence of a roll can be detected as follows:

1. With the test set in the OFF position, plug in the tone test set with the modular connector.
2. Observe the LED. A green LED indicates correct polarity; red means reversed polarity (a 'roll').
- **If this polarity test is performed with the toner connected to a pair using the test clips instead of the modular plug, you must be certain you are connecting the leads to the proper conductor.** Tip is normally positive (connect the black lead) while ring is normally negative (connect the red lead).
- If using central office battery (dialtone) for this test, you must be sure to check polarity during the dialtone BEFORE a number is dialed. Polarity will sometimes be reversed by the central office during completion of a call.

Some people prefer to test polarity with a buttset and tone test set, without dialtone connected. There are several methods that will work. The first method uses the two test devices together:

1. Switch the Leviton tone test set to the CONT position. In this setting, the battery inside the unit is connected to the test leads. Connect the red test lead to ring, and the black lead to tip of the pair under test.
2. Clip on the buttset with the switch in the monitor position. Be sure to observe polarity when connecting the buttset (red lead to ring, black to tip). Indicators on the buttset will show voltage is present and there is proper polarity (refer to your buttset instructions for details).
3. Using a modular breakout adapter, you can plug directly into each device and connect the buttset leads to the adapter.

Some installers prefer to use a 12-volt lantern battery as the source:

1. Simply plug the tone test set directly into each modular jack, instead of using a modular adapter and the buttset clip leads.
2. If polarity appears reversed at ALL devices, first check the network polarity at the demarc jack. Then check at the common connecting point to see if the roll is there, affecting all devices. If the roll appears on ALL devices *beyond a certain point*, check the continuing connections at the device just before that point. If only one device shows a roll, the problem is probably in the connection of that single jack.
- If you discover the pair rolled on the network side, report the problem to the utility. *Do not reverse the inside wiring system to accommodate a network reversal—the network error may be detected at any time and "made normal."* This would reverse your connection again, resulting in a callback.

## 2T.3 FINAL VERIFICATION TESTING

### 2T.3.1 BASIC RESIDENTIAL WIRING VERIFICATION

After the jack has been installed in the outlet, and assuming all other prior tests were successful, final verification testing can be performed with a simple telephone set or a buttset—if dialtone service has been installed. Splitting adapters can be used where necessary to test for multiline service.

1. Connect to the NID (network interface device) at the demarcation point.
2. Go off-hook and receive dial tone.
3. If a test number is available, make a call to it and receive a return call. (Check with the local telephone company about test lines.) Listen for clear transmission without pops, clicks, or scratching sounds. Your office may be able to assist if a test number is not available. In any case, assure that digits dialed will stop dial tone, and that dial tone resumes when the phone is hung up and then taken off hook again.
- If these tests fail, either the line has not been installed, or the fault is in the access lines to the phone company, in which case the phone company should be contacted.

4. Repeat the tests for each of the lines at the demarcation point.
5. Connect the NID to the premises wiring.
6. Go to each outlet in turn and repeat the test for every installed line (at each jack). If a failure is encountered, proceed as follows:
  - Check the connections to the jack for proper connections and check the wiring (including the distribution device and any auxiliary disconnects) to see if any obvious disturbance has occurred since rough-in. Some phones may not work with polarity reversed, so be particularly careful to check wire colors for proper polarity.
  - If no fault is obvious, re-test as for rough in.

*NOTE: If dial tone service is not available, perform the same tests as for rough-in before the jacks were installed. A splitting adapter may be necessary to test each line of each jack. A toner may be used with a normal telephone or buttset to test for dial tone. Most toners will provide an audible tone to the phone as well as sufficient voltage to power the phone to generate touch-tone or rotary dial digits.*

## 2T.4 TESTING SECURITY SYSTEMS

Since FCC Docket 88-57 permits non-carriers to connect wiring and other devices to the carrier's network (on the customer's side of the demarcation point) there is an expanded opportunity for those involved in security systems installation and maintenance. This alarm system troubleshooting section will describe how to use Leviton test equipment to:

- Verify correct installation and operation of alarm and phone system wiring and RJ-31X exclusion-type "dialer jacks," with or without Telco dialtone available.
- Locate and troubleshoot wiring for proper installation of RJ-31X jacks.
- Locate and identify spare pairs in existing premise wiring to facilitate initial alarm installations.
- Locate and use spare wire pairs in establishing alarm systems for more economical upgrades and expansion.

**For Commercial /Category 5 Wiring Verification, see Book 3T.**

**IMPORTANT: The testing of specialized circuits for alarm systems requires special considerations.** Many alarm systems depend on proper polarity to operate, and it is essential that they be tested to assure that they will function in the event of an emergency. Alarm systems also often depend on RJ31X-type USOC jacks with shorting bars to signal that the alarm system has been disconnected (tampered with).

**CAUTION: You may not access, attach, or modify any wiring attached to the protector or on the carrier's side of the demarcation point,** as this would be in violation of FCC rules and regulations. If you have questions about the installation of jacks or other equipment at a customer location, Leviton suggests that you contact the carrier company servicing that customer. Often details are provided in the first few pages of your local phone directory.

### 2T.4.1 TESTING SECURITY SYSTEMS FOR SHORTS AND OPENS (CONTINUITY)

1. With the tone test set mode switch set to CONT, connect the red and black test leads of the Tone Test Set to the loop wires under test.
  - Polarity does not matter in this test. A solid green LED light indicates a closed circuit, a dim LED indicates off hook status, and a pulsing LED indicates a ringing line. If the LED does not light, check for opens in the loop.

### 2T.4.2 LOCATING SECURITY LOOP FAULTS

Use Leviton's Tone Test Set and Speaker Probe to quickly check for opens, faulty active devices, and damaged contacts or switches. These test sets can also locate poor or corroded splices or connections, and foil breaks in the protective circuit, without disturbing any field wiring connections.

1. Clip the Tone Test Set's red lead to either side of the loop while it is disconnected from the alarm panel terminals, and select the TONE position (see Fig. 2T-6).

*Note: For this test to be accurate, attach only one lead to the loop.*

2. Then, with the Speaker Probe, listen at the splice locations for a tone.

- If no tone is heard, then the wiring break is somewhere between that point and the panel.
- If a tone is heard, continue probing the wiring until the tone is lost or greatly attenuated. When the tone diminishes or disappears entirely, a fault is indicated because the signal is no longer carried by the loop circuit.

If the fault is caused by improperly spliced or crimped wire connection, a clean, reliable splice is achieved by using a dedicated splicing/crimping tool.

### 2T.4.3 LOCATING SPARE PAIRS

Installing or upgrading phone and alarm systems is easier and more economical if existing wiring can be used. Use the Speaker Probe and Tone Test Set to trace and identify spare pairs in existing premise wiring. Leviton's Tone Test Set and Inductive Speaker Probe are ideal tools for rapidly troubleshooting alarm systems.

- For instructions on locating spare pairs by tracing tone, see Section 2T.2.4.

### 2T.4.4 TROUBLESHOOTING THE RJ-31X

The RJ-31X exclusion-type "dialer jack" (Fig. 2T-7) is commonly used with security and fire alarm equipment to provide exchange access lines to alarm reporting devices. The phone line is wired in series through the RJ-31X; from there, tip and ring pass through the dialer. A normally closed relay will open if the alarm is activated, seizing the circuit for alarm use, while temporarily disconnecting house phones to avoid disruption of the dialing sequence.

The eight-position, non-keyed miniature jack has shorting bars across terminals 1-4 and 5-8. Inserting the modular plug lifts the contact wires away from the shorting bars, extending the tip and ring circuit to the series leads going into the alarm device. When the plug is removed from the jack, metal tabs inside the RJ-31X provide direct connection of tip and ring back to the other locations, bypassing the alarm device. This design lets the dialer control the line for exclusive use when in alarm mode. *It also permits "phone trouble" to be isolated by unplugging the panel/dialer to route tip and ring directly to house phones.*

Some technicians may install a "shortcut" or depopulated four-terminal version of the dialer jack. In the shortcut dialer jack, the jumpered terminals which supervise the presence of the plug are missing. Consequently, the depopulated version cannot provide a hard-wired, normally closed tamper loop for supervising

FIG. 2T-6. Locating Security Loop Faults

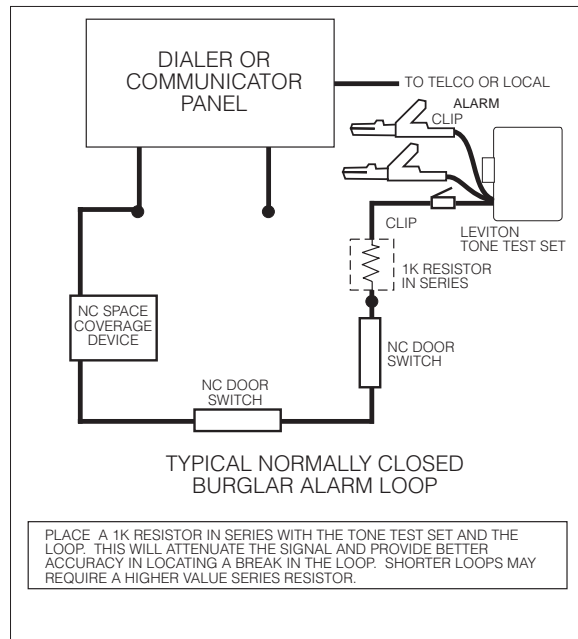

the presence of a modular plug in the jack. If the tamper/trouble indication function is important to your customer, be sure to install a fully populated RJ-31X jack, and properly connect all terminals.

Leviton recommends that the RJ-31X be installed in front of any other jacks in the system so that when an alarm occurs, the automatic dialing unit will take priority and seize the line, *leaving all house phones and wiring disconnected.*

Unless noted otherwise, the tests described in this section require that Telco dialtone be available.

### 2T.4.5 VERIFYING RJ-31X INSTALLATION

With the Tone Test Set switch in the OFF position, connect the tone set leads to terminals 4 (ring) and 5 (tip) of the RJ-31X jack. (See Fig. 2T-7, Test 1.) The LED should glow bright, steady red, indicating voltage is supplied to the line and dialtone is available. A green LED indicates the line is off hook, and a pulsing orange LED indicates a ringing line.

### 2T.4.6 VERIFYING RJ-31X WIRING WITHOUT DIALTONE.

If installation occurs before dialtone is connected, it is especially important to check the panel, dialer, and jack

**BOOK**  
**2T**  
**TESTING & TROUBLE-SHOOTING**  
**RESIDENTIAL AND LIGHT COMMERCIAL WIRING SYSTEMS**



wiring to make certain both alarm and phone will work properly when dialtone is supplied. Note: Without Telco dialtone, polarity cannot be verified, but Telco standard polarity color coding is shown in Fig. 2-2 on page 2-2. Telco installers will observe this color code when connecting dialtone.

1. With the Tone Test Set switch set to TONE, connect the test set leads to terminals 4 (ring) and 5 (tip) of the RJ-31X jack (see Fig. 2T-7, Test 2). *Be sure to observe proper polarity.*
2. Trace the generated tone through the entire circuit with the probe. Tone should be heard throughout.
3. Then, to verify the operation of the alarm dialer, set the alarm panel off and check the house phone wiring with the probe. No tone should be heard on the house wiring. This indicates that the dialer has seized the line.

#### 2T.4.7 VERIFYING POLARITY TO THE PREMISE PHONE SYSTEM

It is important for the alarm installer to verify correct polarity to the premise phone line, especially in old tone telephone systems without polarity guard. In such a system, if tip and ring are reversed and an emergency occurs, the alarm may or may not work, and the phone will not dial out.

1. With the alarm panel in normal, connect the Tone Test Set red lead to terminal 1 (ring) and the black lead to terminal 8 (tip). (See Fig. 2T-7, Test 3.)
- If dial tone is connected to the pair under test, the roll is indicated by the LED. A green LED indicates proper polarity while a red LED indicates 'rolled' or reversed polarity. For more information about polarity testing, see section 2T.2.8.

FIG. 2T-7. RJ-31X Jack Wiring Diagram

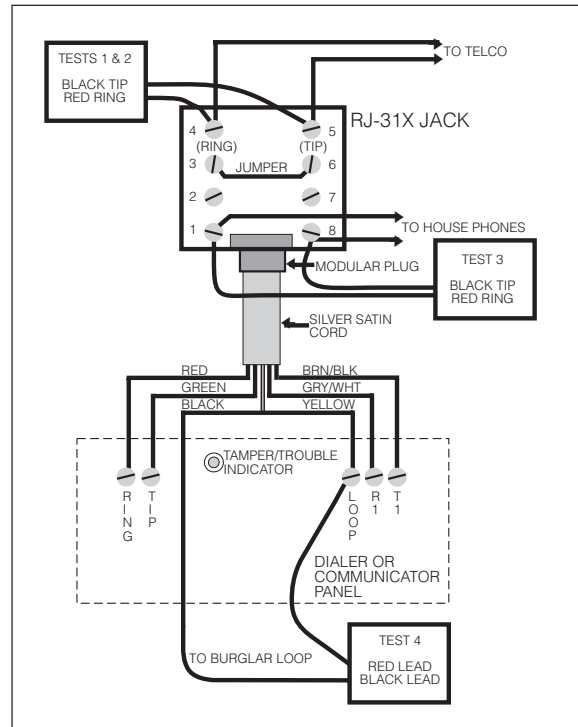

#### 2T.4.8 VERIFYING THE SECURITY SYSTEM TAMPER LOOP

Most alarm systems have a trouble/tamper indicator to alert the owner when the system cannot arm because the alarm's modular plug has been disconnected. **Only a fully-populated, eight-terminal jack can provide a supervisory circuit.** The tamper loop is a normally closed circuit, jumpered at terminals 3-6, that opens upon removal of the plug. Alarm installers can use the toner to verify the tamper loop and ensure that the system will be able to detect this condition.

1. With the Tone Test Set switch set to CONT, connect the test set leads to the black and yellow wires in the alarm control box (Fig. 2T-7, Test 4).
2. Unplug and replug the modular jack several times to verify that the trouble indicator lights up when the modular jack is removed.
- Remember, this test cannot be performed with the "shortcut" version of the RJ-31X.

## CATEGORY 5 CABLE TESTERS – MANUFACTURER LISTING

To ensure Category compliance of installed wiring, a hand-held cable tester should be used. The following companies manufacture hand-held Category 5 cable testers. This information is listed as a courtesy for your reference only and is not an endorsement nor a recommendation. You are advised to contact each company directly to request detailed information about each product. Some of these companies also sell their product through other companies under other product names; you are advised to ask which of these companies is the actual manufacturer of the tester.

### Datacom Technologies

11001 31st Place West  
Everett, WA 98204  
800-468-5557  
425-355-0590  
Fax: 425-290-1600  
www.datacomtech.com (website)  
info@datacomtech.com (email)

### Product

LANcat® Installer Cable Tester, LANcat® System 5 Cable Tester and Talk Set, Optical Loss Measuring System LANcat® System 6 Cable Tester and Talk Set, FIBERcat™

### Fluke Corporation

P.O. Box 9090, MIS 250E  
Everett, WA 98206  
800-44-FLUKE (Customer Support)  
www.fluke.com/nettools/ (website)

### Product

DSP-100 CableMeter, DSP-100/SR Cable Meter  
DSP-2000 CableAnalyzer, DSP-FTK Fiber Test Kit (MM), LS-1310/1550 Fiber Test Kit (SM)  
Fluke 140 Tone Probe & Fluke 620 LAN Cable Meter

### Microtest, Inc.

4747 North 22nd Street  
Phoenix, AZ 85016-4708  
800-526-9675  
602-952-6400  
Fax: 602-952-6401  
www.microtest.com (website)  
sales@microtest.com (email)

### Product

PentaScanner 350  
PentaScanner 8150-00

### Scope Communications, Inc.

753 Forrest Street  
Marlborough, MA 01752  
800-418-7111  
508-786-9600  
Fax: 508-786-9700  
www.scope.com (website)  
sales@scope.com (email)

### Product

Wirescope 155 Cable Analyzer, Part No. 500-5200  
Fiber SmartProbe+, Part Number 500-5265

### Wavetek

9145 Balboa Ave  
San Diego, CA 92123  
800-854-2708  
619-279-2200  
Fax: 619-627-0132  
www.wavetek.com (website)

### Product

LT 8000, LT 8100, LT 8155



## INSTALLATION PRACTICES FOR COMMERCIAL BUILDINGS (TIA-568-A COMPLIANCE)

*In addition to the installation practices for Residential and Light Commercial buildings in Book 2, the practices in this section should be followed in order for a horizontal cabling installation in Commercial buildings to comply with TIA-568-A.*

**IMPORTANT:** Please read all warnings and cautions on page 1-6.

**Scope:** This Guide only covers horizontal cabling, not backbone cabling. Backbone cabling for the MDF, IDF, Equipment Room and Telecommunications Closet is beyond the scope of this document. This is due to the fact that backbone cabling in TIA-568-A is very application and building specific, and dependent upon the type of communications, type of building, and many other issues. Thus for backbone and crossconnect design and installation the user is cautioned to refer to the TIA-568-A standard document and if necessary, communications consultants. But in general, the specifications for backbone wiring are:

- **a maximum of two levels**
- **star topology**
- **limited to 90 meters for Category-rated applications; 800 meters for voice applications.**

*Horizontal* cabling in TIA-568-A, on the other hand, is a generic cabling system. If horizontal cabling is installed according to the practices in the standard, the system will be sufficient for the majority of applications for which it will be used.

For the purposes of this section, horizontal cabling is considered the cabling from the work area to the telecommunications closet. It includes the crossconnects in the telecommunications closet; horizontal cable; and the outlet at the work areas.

**Note on Scope Of TIA-568-A:** TIA-568-A covers only the building's cabling systems, not the pathways such as conduit or raceways. Commercial building pathways and spaces for telecommunications wiring are covered in a separate standard, TIA-569. Grounding is covered in TIA-607.

### 3.1 BENEFITS OF TIA-568-A COMPLIANCE

Commercial building horizontal cabling that is installed in accordance with the TIA-568-A standard is like having one type of foundation that can support any type of structure that is built upon it—even if the structure keeps changing. The benefits are that you have one system which will:

- Simplify ongoing maintenance, relocation, and addition;
- Accommodate future equipment and service changes;
- Accommodate a diversity of user applications, including voice, data, LAN, switching, and other building services.

#### 3.1.1 STAR TOPOLOGY

**TIA-568-A specifies a star topology: a hierarchical series of distribution levels.** In the backbone are the main distribution frame (MDF) and the optional intermediate distribution frame (IDF). Only one IDF is allowed between the MDF and telecommunications closet.

FIG. 3-1. Typical Commercial Building Wiring Topology

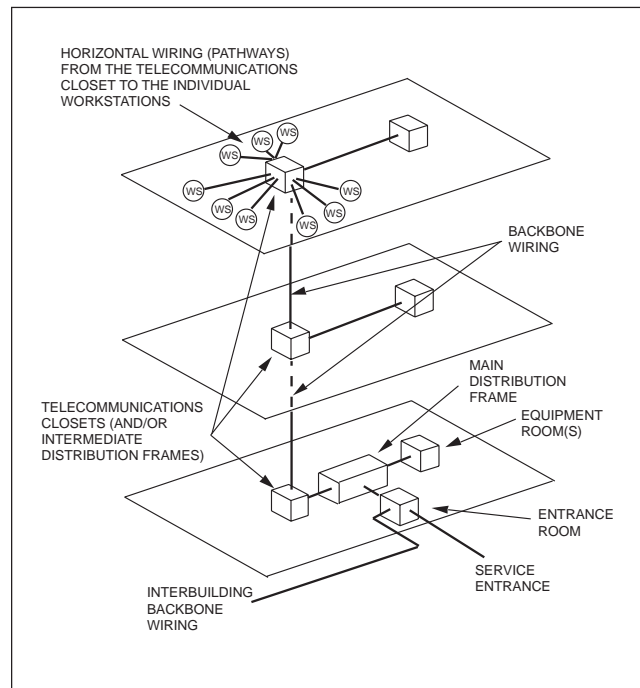



**Figure 3-2.** Typical Commercial Wiring Topology.

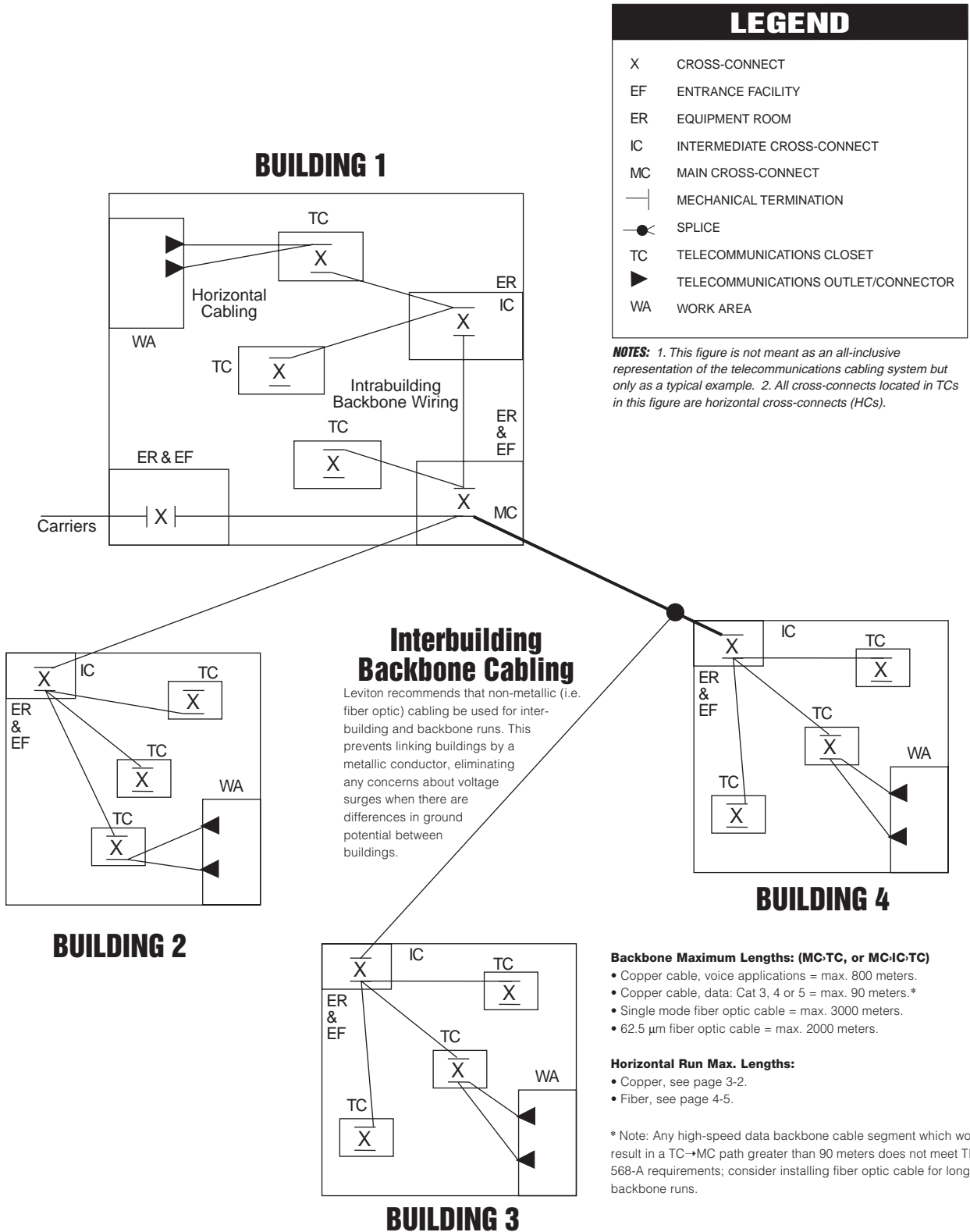

**BOOK 3**

**COPPER CABLING FOR COMMERCIAL APPLICATIONS**

**TIA 568-A**

Compliant Installation

The first level, the MDF, links to other levels via the backbone cabling. The MDF may link to the third and final level, the telecommunications closet (TC) directly, or in large installations it may link to some TCs via an optional second level, the intermediate distribution frame (IDF). The TC terminates the backbone cable and cross-connects to the horizontal cabling. The horizontal cabling terminates in the work area at the workstation (WS). The TC and work area must be on the same floor. (See Fig. 3-1.)

The EIA/TIA-568-A wiring system is based upon a star wiring topology. In a star topology, all phones or workstations are wired directly to a central location. The star topology accommodates direct connection applications (10Base-T, 100Base-T), bus applications (Ethernet with some restrictions), and daisy chain applications (IBM Token Ring and 5250). Most applications can operate on any of the three designated cabling systems, but some applications will require low-cost external devices called baluns to interface coaxial applications hardware to UTP wiring systems.

The EIA/TIA standards are designed to be generic to allow multiple vendors' components of the same Category rating to be used successfully in the same system. As another benefit, a TIA standard-compliant cabling system can accommodate future equipment and service changes to simplify ongoing maintenance and relocation.

In the star topology for commercial installations, each piece of user's equipment (such as a phone or terminal) connects directly to the common equipment in the telecommunications closet or equipment room. A minimum of two cables are run to each user's work area, usually one for voice and one for data.

### 3.1.1.1 COMMERCIAL TELECOMMUNICATIONS OUTLETS

The telecommunications outlet must be an 8-position jack wired to T568A or T568B pin/pair assignment.

### 3.1.1.2 ALLOWED CABLING SYSTEMS

Voice cable and connections (i.e. jacks) are four-pair 100 ohm UTP. For full compliance, jacks must be wired to one of the two TIA-specified pin/pair assignment, called T568A or T568B and all four pairs must be terminated.

Data cable and connections can be any of the following: four-pair 100 ohm UTP, commonly used for 10Base-T; 150 ohm STP, commonly used for token ring or 62.5/125 um optical fiber, commonly used for fiber distributed

data interface (FDDI). Each cable type was chosen for its large installed base, multiple vendors and applications, and low cost. In the backbone are the main distribution frame (MDF) and the optional intermediate distribution frame (IDF). (See Figure 3-1.) Only one IDF is allowed between the MDF and telecommunications closet.

### 3.1.1.3 Equipment Locations

- **Communications equipment (phones, fax machines, computers, etc.) may be located in any space**—work areas, TCs, distribution frames, or a separate space called an equipment room.

### 3.1.1.4 Non-Star Topologies

- **Bus, tree and ring topologies are implemented in the telecommunications closet or other crossconnects rather than directly between work areas. Application distance limitations must be checked.**

## 3.1.2 MAXIMUM HORIZONTAL DISTANCES

- **Horizontal closet-to-workstation run: Maximum cable length from the mechanical termination of the media in the TC to the telecommunications outlet is 90 meters (295 feet), independent of media type.**
- **Splices and bridged taps are not allowed** as part of the horizontal cabling, (except as noted in transition point and consolidation point below.)
- **Only one transition point is allowed** between flat undercarpet cables and one of the recognized horizontal cables.
- **MUTO and Consolidation Points are covered in TSB-75.**

**MUTO-(Multi-User Telecommunications) Outlet** is the same as a standard outlet, except it services more than one workstation area (longer patch cords are allowed).

**Consolidation Point**-This is a splice point for wiring going to an open office area. No patching is allowed in a consolidation point and no transition point is allowed where a consolidation point is used. The consolidation point must be attached to a permanent building structure (outside wall, load-bearing wall, ceiling beam, etc.)

- **Length of work area equipment cable: It is suggested that the maximum equipment cable length**

from the telecommunications outlet to the work area equipment be limited to 3 meters (10 feet).

- In addition, it is suggested that the **maximum cable length for jumpers and patch cords in the telecommunications closets be limited to 7 meters (23 feet)**, with no single cord exceeding 6 meters; see Figure 3-3. A maximum of 2 patch cords is allowed per horizontal run.
- **It is suggested that equipment cables meet or exceed patch cable performance requirements.**

### 3.1.3 HORIZONTAL CABLING SYSTEMS

- **There must be a minimum of two cabling runs from the telecommunications closet to each individual work area.** The requirement of having two cabling runs is due to the importance of both voice and data telecommunications in a commercial building, and to allow implementation of bus and ring topologies. **TIA-568-A realizes that most work areas will require both voice and data telecommunications within the lifetime of the cabling system, and so requires that all work areas be wired with a minimum of two outlets.**

- **The required two horizontal cabling runs to each work area shall be as follows:**

- 1) One shall be a four-pair 100Ω UTP.**
- 2) The other/second shall be one of:**
  - a) Four-pair 24 AWG 100Ω UTP, or
  - b) Two-pair 150Ω STP, or
  - c) Two-strand, 62.5/125 μm optical fiber.

- **Hybrid cables (consisting of more than one of the above recognized cables under a common sheath) may be used in the horizontal cabling provided that they meet the hybrid cable requirements in TIA-568-A.**
- **Coaxial cable (allowed, but not part of a compliant system).**

#### 3.1.3.1 Horizontal Cabling System Selection

There are three types of cable recognized for standard-compliant installation: 100Ω UTP, 150Ω STP and 62.5/125μm fiber optic cable.

**FIG. 3-3.** Cross-Connect topology with Maximum Horizontal Distances vs. Interconnect topology.

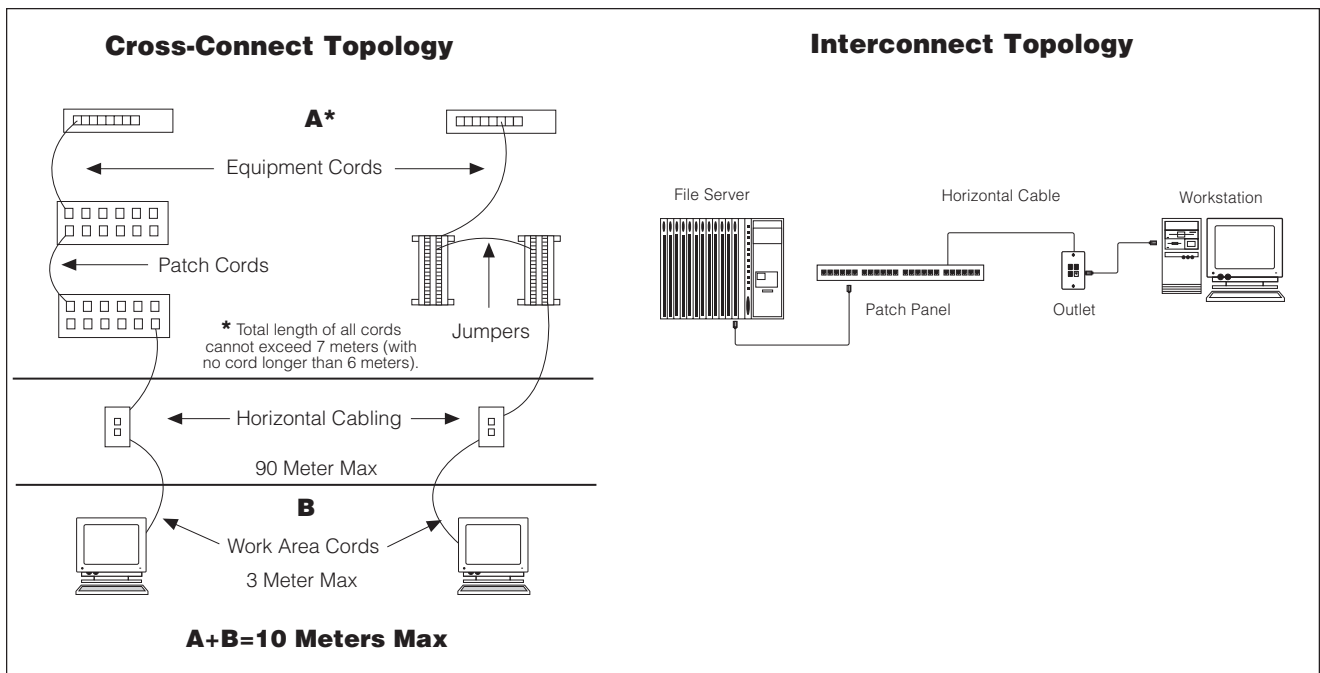

100 $\Omega$  UTP is the most universal cabling system and generally the least expensive. It covers almost all applications up to 100 MHz with a minimum of cost. The user must decide which category of 100 $\Omega$  UTP cabling system is needed for the application. For voice cabling systems, Category 3 is sufficient; for data cabling systems, Category 5 is highly recommended.

150 $\Omega$  STP is usually installed as a hybrid system, consisting of one 150 $\Omega$  STP data cabling system and one 100 $\Omega$  UTP Category 3 voice cabling system under one sheath. 150 $\Omega$  STP is usually used for token ring applications, but the extended bandwidth 150 $\Omega$  STP has application hardware for broadband video up to 300 MHz and 155 Mbps ATM.

Optical fiber is typically the most expensive cabling system to install, but it has the widest bandwidth (in excess of 1 GHz). While optical fiber is not practical for voice and other low bandwidth applications in the horizontal, optical fiber should be the cabling system choice for high bandwidth applications such as FDDI, ATM, broadband video and multiplexed signals.

**For specific cabling system requirements, see Sections 3.2 (100 $\Omega$  UTP), 3.3 (150 $\Omega$  STP) and Book 4 (optical fiber).**

### 3.1.3.2 Cabling System Components

Each cabling system is composed of four main components:

- 1) Telecommunications outlet
- 2) Horizontal cable
- 3) Crossconnect hardware
- 4) Patch cables, equipment cables and jumpers

The telecommunications outlet is in the work area and provides access to the building tele communications cabling system.

Horizontal cables connect the work area outlet to the crossconnect system in the telecommunications closet.

Crossconnect hardware terminates the horizontal cable, backbone cable, and equipment in the telecommunications closet.

Patch cables and jumpers connect crossconnect hardware in the telecommunications closets.

Equipment cables connect telecommunications equipment to the outlet in the work area or to the cross connects in the telecommunications closet (see Section 3.4 for more information on TC crossconnects).

- **Per the National Electrical Code<sup>®</sup>, each component must be listed for the purpose.** Look for the UL or ETL listing for each component (CSA in Canada).
- **All components must comply with FCC Part 68** (CS-03 in Canada). Look for the compliance statement on the component or the component packaging. Wire and cable are listed with the FCC.

**Each cabling system, along with its components, is described in the sections to follow.**

### 3.1.3.3 Other Cabling Systems

- **If you need to include other cabling systems but still wish to have a TIA-568-A compliant installation, other cabling systems may be included to the work area, as long as they are in addition to the two TIA-568-A required cabling systems.** Examples of additional cabling systems are IBM 3270 on RG-62U or 100 $\Omega$  UTP with baluns; video on RG59, Category 5 100 $\Omega$  UTP or 150 $\Omega$  STP, LonWorks; and voice on 25 pair 100 $\Omega$  UTP.

## 3.1.4 GROUNDING & BONDING CONSIDERATIONS

Grounding and bonding systems are normally an integral part of the specific application or telecommunications cabling system that they protect. They protect personnel and equipment from hazardous voltages, and reduce the effect of electromagnetic interference (EMI) to and from the telecommunications cabling system. **Improper grounding and bonding can induce voltages which disrupt telecommunications circuits.**

- **Grounding and bonding shall meet the National Electrical Code (NEC) requirements and practices,** except where other authorities or codes impose a more stringent requirement or practice.
- **Additionally, grounding and bonding shall conform with TIA-607 requirements** for telecommunications infrastructure.
- **Grounding and bonding instructions and requirements of the equipment manufacturer should also be followed.** Grounding and bonding requirements of specific data and telecommunications networks could possibly exceed the grounding and bonding requirements of the national or local requirements or practices.

## 3.2 100Ω UTP CABLING SYSTEMS

100Ω UTP cabling systems currently are the most versatile and often the most cost effective. They cover almost all applications up to 100 MHz with a minimum of cost.

100Ω UTP cabling system components have been categorized into performance groups. Each performance group characterizes the performance of the components up to a specific frequency:

**Category 3:** up to 16 MHz (10 Mbps)

**Category 4:** up to 20 MHz (16 Mbps)

**Category 5:** up to 100 MHz (100 Mbps)

For category selection for a specific application, refer to Section 1. A general rule of thumb is to use Category 3 for voice cabling systems, and Category 5 for data cabling systems.

- **As a minimum for any category-rated installation, make sure all components are at least of the minimum category required.** Just as a chain is no stronger than its weakest link, the lowest category-rated component in a system reduces the entire cabling system to that category.

### 3.2.1 100Ω UTP WORK AREA OUTLETS

- **Generally, screw terminations for cable outlets limit an outlet to Category 3 performance.**
- **Category 4 outlets usually terminate on an insulation displacement connector (IDC)** such as 110, and internal leads are twisted and are often limited to less than 8" in length.
- **Category 5 outlets always use an IDC for cable terminations,** and have internal compensation to meet the transmission requirements.

#### 3.2.1.1 100Ω UTP Work Area Outlet Installation

- **Each four-pair cable shall have all pairs terminated on an eight-position jack.**
- **Pin/pair assignments shall be as per T568A, or T568B** (Figure 3-4). T568A is the new pin-out scheme and is generally used for analog voice applications using 2 lines. T568B is the more common pin-out scheme, and is generally used for multi-line electronic key systems and most data applications. Either will comply with most voice and data applications including ISDN, 10BASE-T, 16 Mbps token ring and ATM.

- **Maintain the twists of the cable as close to the termination on the outlet as possible, to maintain the transmission characteristics of the category. Category specifications require that pair twisting be maintained to within the following distances from the outlet termination:**

**Category 3** max. allowed untwisting: **3"**

**Category 4** max. allowed untwisting: **1"**

**Category 5** max. allowed untwisting: **1/2"**

**Above Category 5** allowed untwisting: **<1/2"**

*Note: TIA-568-A does not specify the maximum allowable untwisting for Category 3 UTP, but 3" is suggested as the maximum distance for standard practice.*

- **Leave a sufficient service loop of the horizontal cable for future adds, moves and changes.** Usually  $\frac{1}{3}$  to 1 meter (1 to 3 feet).
- **Each telecommunications outlet must comply with pair color codes or have a conversion chart shipped with each outlet.** Pair color codes are as shown in Table 3-1.
- **The bend radius of the cable must be no tighter than four times (4x) the cable's outside diameter, at any point in the horizontal channel** (such as pathway corners, and station outlet entrances and service loops). For four-pair UTP plenum cable, this translates to about a 1" bend radius.
- **For multi-pair cable (>4 pairs; typically 25-pair), the minimum allowed bend radius is 10x the outside diameter.**

Fig. 3-4 EIA/TIA-568-A Compliant Wiring Configurations.

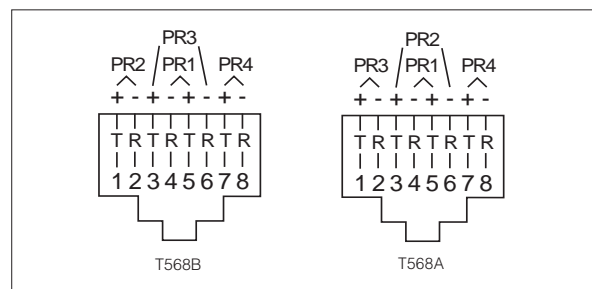



TABLE 3-1. Telecommunications Wiring Color Codes.

Wire Pair # and Lead Functions	Banded Colors	Semi-Solid Colors	Cat 5 Solid Colors (tightly twisted together)	8-Position T568A Jack Pin #	8-Position T568B Jack Pin #	6-Position Jack Solid Colors*	6-Position RJ25 USOC Jack Pin *
1 Tip 1 Ring	White-Blue Blue-White	White-Blue Blue	White Blue	5 4	5 4	Green Red	4 3
2 Tip 2 Ring	White-Orange Orange-White	White-Orange Orange	White Orange	3 6	1 2	Black Yellow	2 5
3 Tip 3 Ring	White-Green Green-White	White-Green Green	White Green	1 2	3 6	White Blue	1 6
4 Tip 4 Ring	White-Brown Brown-White	White-Brown Brown	White Brown	7 8	7 8		

Note: The wire insulation is white, and a colored marking is added for identification (see Book 2, Section 2.1.1 on band-stripped color marking). For cables with tightly twisted pairs (all less than 38.1mm [1.5 inches]) the mate conductor may serve as the marking for the white conductor. A white marking is optional. \*Added for informational purposes only; does not comply with EIA/TIA-568-A.

### 3.2.1.2 Installing Outlets for Cabling Systems in Addition to the Minimum TIA-568-A Cabling System

Any 100Ω UTP modular jack or adapter may be added to the minimum cabling system outlet, as long as the minimum cabling system for TIA-568-A is met. Baluns, 6 position USOC, 8 position USOC or MMJ outlets may be added to the work area telecommunications outlet as required by the specific site.

### 3.2.2 100Ω UTP CABLING SYSTEMS

- The unshielded inside cable used in the horizontal cabling system is 24 AWG thermoplastic insulated conductors formed into four individually twisted pairs and enclosed by a thermoplastic jacket.
- Four-pair 22 AWG cables may be used if they meet the physical transmission requirements of the desired Category.
- Four-pair screened twisted pair (100Ω STP) cables may be used if they meet the physical and transmission requirements of the desired Category.
- Undercarpet cables may be used for certain applications, but only one transition point from round cable to flat undercarpet cable is permitted

on any horizontal run. Undercarpet cables shall meet ANSI/IPC-FC-21 and must be listed for that purpose.

### 3.2.2.1 100Ω UTP Cable Installation

- For TIA-568-A compliant installations, do not exceed 25 lbs. of pulling tension on the cable (4-pair, 24 gauge).
- Do not chafe or damage the outer jacket of the cable. Watch out for sharp corners, screws, nails, or excess flashing that may cut or chafe the jacket.
- Installation in colder climates may require cables with special jackets. PVC and other jacket materials may require treatment to remain flexible in the colder regions.
- The wire color code shall be as shown in Table 3-1.

➔ See "Do/Don't" Installation Guide beginning on page 3-15.

### 3.2.3 100Ω UTP CABLING SYSTEM TELECOMMUNICATIONS CLOSET CONNECTING HARDWARE

The telecommunications closet is where connecting hardware for 100Ω UTP cable is installed as a means of connecting the horizontal cabling to the backbone cabling or equipment.

Two types of crossconnects are common: patch panels and crossconnect blocks.

Patch panels often have the backbone cable, horizontal cable, or electronic equipment cord directly terminated on the cable terminations. Crossconnecting is achieved by patch cords.

Crossconnect blocks are usually IDC connections with the electronic equipment cords, horizontal cables and backbone cables terminated on one side. The crossconnect jumpers terminate to the other side of the block, and between blocks to complete the crossconnect.

- **It is desirable that hardware used to terminate cables be of the insulation displacement connector (IDC) type.** Screw terminals are not recommended except as required for specific applications. See Table 3-2.

**TABLE 3-2.** Termination Hardware for Category-Rated Cabling Systems.

Termination Hardware	Category 3	Category 5	Beyond Category 5
Screw terminals	(1)	-	-
25 pair connector	(2)	(2)	-
66-clip	Yes	(2)	-
110	Yes	Yes	Yes

Note (1): If the application specifically requires it.

Note (2): Some versions comply; check with the manufacturer.

#### 3.2.3.1 100Ω UTP Connecting Hardware Installation

- **Install connecting hardware in a neat, well organized manner,** using wire management and mechanical termination practices in accordance with manufacturer's guidelines.
- **Connecting hardware must be organized into connecting fields for ease of administration;** see Section 3.4, Telecommunications Closet.
- **Document the installation, and use color coding and labeling;** see Section 3.5, Administration.

- **Preserve wire pair twists as closely as possible to the point of mechanical termination, in order to minimize signal impairment.** This will maintain the transmission characteristics of the category. Category specifications require that twisting be maintained to within the following distances from the outlet termination:

**Category 3 UTP** = 3" max. untwisting\*

**Category 4 UTP** = 1" max. untwisting

**Category 5 UTP** = 1/2" max. untwisting

**Above Category 5 UTP** = <1/2. untwisting

\*NOTE: TIA-568-A does not specify allowed untwisting for Category 3, but 3" is suggested as the maximum distance.

### 3.2.4 100Ω UTP CROSSCONNECT JUMPERS, PATCH CORDS AND EQUIPMENT CORDS

- **The summed lengths of the jumpers, patch cords and equipment cords should not exceed 23 feet (7 meters) in length in the telecommunications closet.**
- **It is preferable to buy pre-manufactured patch and equipment cords made to the required lengths** since in-the-field installation of modular plugs on equipment and patch cord cable can be difficult for category compliance.
- **The twists of the individual pairs must be maintained up to and into the plug. This is especially crucial for Category 5 applications.** For Category 5, the twist must be maintained to within .5" of the front of the plug. See Table 3-3 for correct wiring of Category 5 patch cords.
- **Modular plugs for solid wire provide the best connection on TIA compliant patch cord cable.**
- **Use only the modular plug crimping tool recommended by the plug manufacturer.**
- **Patch cord cable must be Category compliant. Tinsel cordage ("silver satin") is not acceptable.**

#### 3.2.4.1 100Ω UTP Crossconnect Jumpers

- **TIA-568-A requires that all jumper cables comply with Category transmission requirements.** These jumpers may be 1 through 4 pairs.

**TABLE 3-3.** Patch Cord Wire Color Codes.

Conductor Identification (1)	Wire Color
Pair 1 + Pair 1 -	White (2) Blue (3)
Pair 2 + Pair 2 -	White (2) Orange (3)
Pair 3 + Pair 3 -	White (2) Green (3)
Pair 4 + Pair 4 -	White (2) Brown (3)

Notes: (1) + = Tip, - = Ring  
 (2) Mostly white wire may have the associate color as a band or stripe.  
 (3) Mostly colored wire may have white as a band or stripe.

### 3.2.4.2 100Ω UTP PATCH CORDS

- TIA-568-A requires all patch cords to comply with category transmission requirements. However, patch cords are allowed additional attenuation so that a more "lossy" (less stringent attenuation characteristics) flexible cable may be used.
- It is recommended that stranded, twisted conductor patch cords be used. Flat, silver satin patch cords do not comply with any Category. Both solid or stranded conductors can be used. The trade-off is that while the solid conductors may provide superior electrical performance, the stranded cords provide better flex life.
- Patch cords do not reverse the wires with the plugs. Pin 1 of end 1 connects to pin 1 of end 2. (See Fig. 3-5b.)

### 3.2.4.3 100Ω UTP Equipment Cords

- Although equipment cords are supplied by the equipment vendor, TIA-568-A does require that they meet the same performance criteria as patch cords, and comply with Category transmission requirements. The one exception is equipment cord for analog telephones, such as "500" sets. Ordinary flat, silver satin equipment cords may be used for analog telephones.
- Maximum length for work area equipment cords is 10 feet (3 meters).

- In the telecommunications closet, the summed lengths of the equipment and patch cables and jumpers together should not exceed 7 meters (23 feet) total.
- Equipment cords for data applications usually do not reverse the wires with the plugs; pin 1 of end 1 connects to pin 1 of end 2. (Fig. 3-5b.)
- Equipment cords for analog telephones usually reverse the wires with the plugs; (i.e., pin 1 of end 1 connects to pin 6 of end 2. See Fig. 3-5a.)

**FIG. 3-5.** (a) Reversed and (b) Straight-Through Pin-Outs.

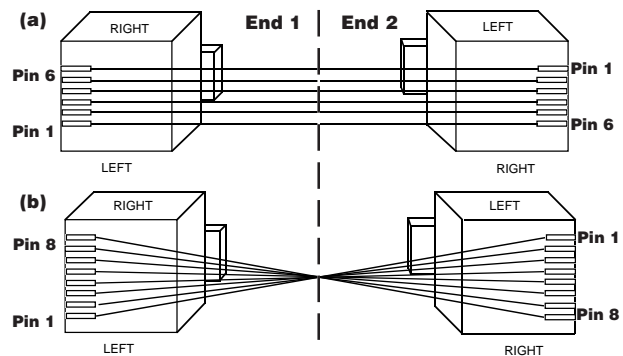

## 3.3 150Ω STP CABLING SYSTEMS

Two 150Ω STP cabling systems exist today. The initial (and unnamed) version is characterized to 20 MHz and is applicable for token ring applications up to 16 Mbps. The new version is the "Extended" 150Ω STP, sometimes called "1A" (in reference to the extended version designator for the new Type 1 cable).

The Extended 150Ω system is characterized to 300 MHz and is not only applicable for token ring applications up to 100 Mbps, but is also being suggested for broadband video. TSB-53 defines the extended 150Ω STP. In TIA-568-A, the extended cabling system replaces the initial version.

Extended components will be designated either by an "A" following the type designation on the cables, or an "E" or the word "EXTENDED" on the cable and connector.

Upgrading existing 150Ω STP cabling systems to the Extended 150Ω cabling system will not usually require replacing the cable. Contact the cable vendor to see if the existing cable meets the Extended requirements, which most existing cables exceeded. However, the connector will still have to be replaced, as the initial connector falls short of meeting requirements for Extended systems.

**BOOK 3**  
**COPPER CABLING FOR COMMERCIAL APPLICATIONS**  
**TIA 568-A**  
 Compliant Installation

### 3.3.1 150Ω STP OUTLET

- The telecommunications connector to be used for terminating the 150Ω STP cable shall be that specified by ANSI/IEEE 802.5 for the media interface connector. This connector is hermaphroditic in design (having both male and female connector elements) so that the two identical units will mate when oriented 180° with respect to each other.
- The new extended version (specified in TSB-53) will be matable with the old version. It is recommended that the extended version be used in all new installations.

#### 3.3.1.1 150Ω STP Outlet Installation

This connector generally is installed directly on the horizontal cable at the work area, or in the telecommunications closet.

- It is suggested that a 1 to 3 foot (1/3 to 1 meter) service loop be added at both locations for adds, moves and changes. Keep in mind that this may be difficult with the cable, due to its large size.

### 3.3.2 150Ω STP CABLE

- 150Ω STP cable must meet the requirements of EIA Interim Standard Omnibus Specification, NQ-EIA/IS-43, and the Detail Specifications listed in the standard.

#### 3.3.2.1 150Ω STP Cable Installation

In addition to the cable installation practices in Book 2:

- Do not exceed the manufacturer's recommendations for pulling tension.
- Do not chafe or damage the outer jacket of the cable. Watch for sharp corners, screws, nails or excess flashing that may cut or chafe the jacket.
- Installation in colder climates may require cables with special jackets. PVC and other jacket materials may require treatment to remain flexible in colder regions.

### 3.3.3 150Ω STP TELECOMMUNICATIONS CLOSET CONNECTING HARDWARE

Patch panels and passive or electronic hubs are the usual crossconnect hardware. Crossconnect blocks are rarely used and are not recommended. Termination of the backbone and horizontal cables is usually to either a 150Ω STP media interface connector, or to an IDC on the patch panel.

#### 3.3.3.1 150Ω STP Crossconnect Panels

Patch panels are generally one of two types: an open panel with a hole for the 150Ω STP media interface connector to snap into, or a panel with IDCs for termination of the building cables.

- In either case, follow the manufacturer's recommendations for termination.
- Allow 1 to 3 feet (1/3 to 1 meter) of service loop for future adds, moved and changes.
- For 19-inch (483-mm) rack-mounted cross-connect panel installations, allow room on the rack for possible telecommunications equipment associated with the 150Ω STP cable.
- Racks should have at least the following clearances for access and cable dressing space:
  - 30 inches (762 mm) in the rear
  - 36 inches (915 mm) in the front
  - 14 inches (356 mm) on the side

#### 3.3.3.2 150Ω STP Hubs

Passive or active hubs usually are connected via the 150Ω STP media interface connectors and patch cords to the horizontal cabling. Backbone cables may be optical fiber or 150Ω STP cables, and are usually connectorized and connected directly to the hub to minimize connections. In either case, follow the recommendations for 150Ω STP patch panels.

#### 3.3.3.3 150Ω STP Patch Cords and Equipment Cords

##### 3.3.3.3.1 150Ω STP Patch Cords

150Ω STP patch cords are usually purchased items and are not normally constructed in the field.

- If field construction is required, follow the patch panel or hub vendor's recommendations.

- Patch cord length should be limited to 23 feet (7 meters).

### 3.3.3.3.2 150Ω STP Equipment Cords

The 150Ω STP equipment cords are usually provided by the equipment vendor and are not normally constructed in the field. If field construction is required, follow the equipment vendor's recommendations.

- Equipment cord length should be limited to 10 feet (3 meters).

## 3.4 THE TELECOMMUNICATIONS CLOSET

The Telecommunications closet (TC) is the hub of the horizontal cabling system and is the key to a well organized horizontal cabling system. Since all telecommunication transmissions to and from the work area end up in the TC, the organization of the TC is critical for future adds, moves and changes. See Figure 3-6 for general closet layout.

First, the telecommunications closet must be sufficient in size to handle the crossconnect field, the associated electronic equipment, the backbone and horizontal cables, and the pathways (conduits, etc.) for the cables—and still have enough room for a craftsman to work, without disrupting services. **The following specifications are from the Pathways Standard, TIA-569.**

There should be one TC per floor, dedicated to telecommunications. If there are multiple TCs on a floor, they shall be interconnected by a minimum one trade size 3 conduit.

- **The TC serving an office area should be of a specific minimum size to accommodate the current and future services in the area served (see Table 3-4).** These sizes may seem a little large, but the TC needs to have enough room to allow electronic equipment to be added for voice, data, video, security, etc.
- **Lighting shall be adequate** (minimum of 50 footcandles) so that craftsmen can distinguish small lettering and work with the small wires.
- **Enough electrical service and outlets** to provide power for the installed electronic equipment and the craftsman's equipment.
- **Clean and free of clutter.**
- **Dedicated to telecommunications.** The TC should not be a storage room.
- **Climate controlled.** Most electronic equipment designed for telecommunications closets requires a limited temperature environment. Separately controlled heating and air conditioning for the TC are almost always required.
- **Secure.** Businesses rely heavily on their communications systems, so access to the TC must be limited to authorized personnel. The door should be lockable.

FIG. 3-6. Typical Telecommunications Closet.

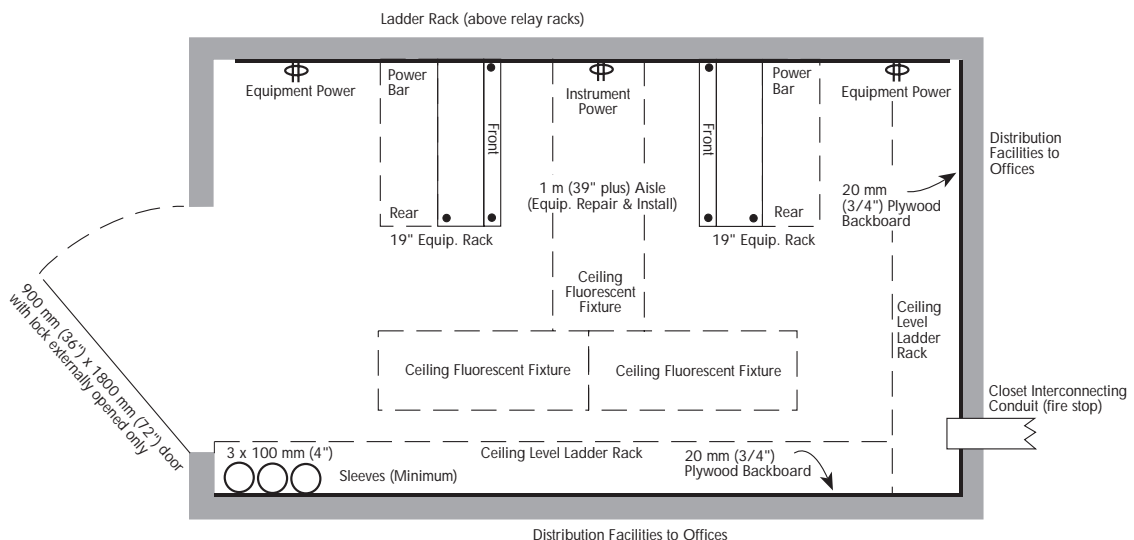



**TABLE 3-4.** Minimum Recommended TC Sizes.

Serving Area:		Closet Size:	
ft <sup>2</sup>	(m <sup>2</sup> )	ft. x ft.	(m x m)
10,000	(1000)	10 x 11	(3 x 3.4)
8,000	(800)	10 x 9	(3 x 2.8)
5,000	(500)	10 x 7	(3 x 2.2)

- Located in a room other than the power distribution or mechanical equipment (heating, ventilation and air conditioning).
- Door width shall be 36"; it should be lockable and open outward.
- The TC shall be firestopped - sleeves, slots, penetration, etc.

### 3.4.1 TC CROSSCONNECT FIELDS

TC crossconnect fields must be well organized to facilitate installation and changes, as this is the key to an easy-to-administer system.

- Crossconnects are usually mounted on a plywood backboard mounted to the walls of the TC (see Fig. 3-7). The crossconnects are usually organized first by cable type (backbone, horizontal, equipment). Then they are often color-coded and organized into cabling system types and services due to the crossconnects required:

- Category 3 IDCs for voice (Category 3 100Ω UTP)
- Category 5 IDCs or patch panels for applications using Category 5 100Ω UTP
- Extended 150Ω STP patch panels for 100 MHz token ring
- Optical fiber patch panels for FDDI
- EIA/TIA-606 suggests that TC crossconnects be organized into color coded fields. Most crossconnect devices can have colored labels or markers added for identification (Table 3-5).
- Sufficient space and hardware must be provided to handle the size and weight of the backbone cables, horizontal cables, patch cords and jumper cables.
- Provide a service loop at each termination for future adds, moves and changes.
- For 100Ω UTP and 150Ω STP, only use jumper cables, patch cords, and crossconnect devices that comply with the Category or extended requirements of the cabling system. Use of lower performance components will cause performance degradation, poor quality signals, and possible data loss.

### 3.4.2 TC ELECTRONIC EQUIPMENT

With increasing use of communications by each person in a commercial environment, the TCs are being equipped

**FIG. 3-7.** Voice & Data Backboards in the TC.

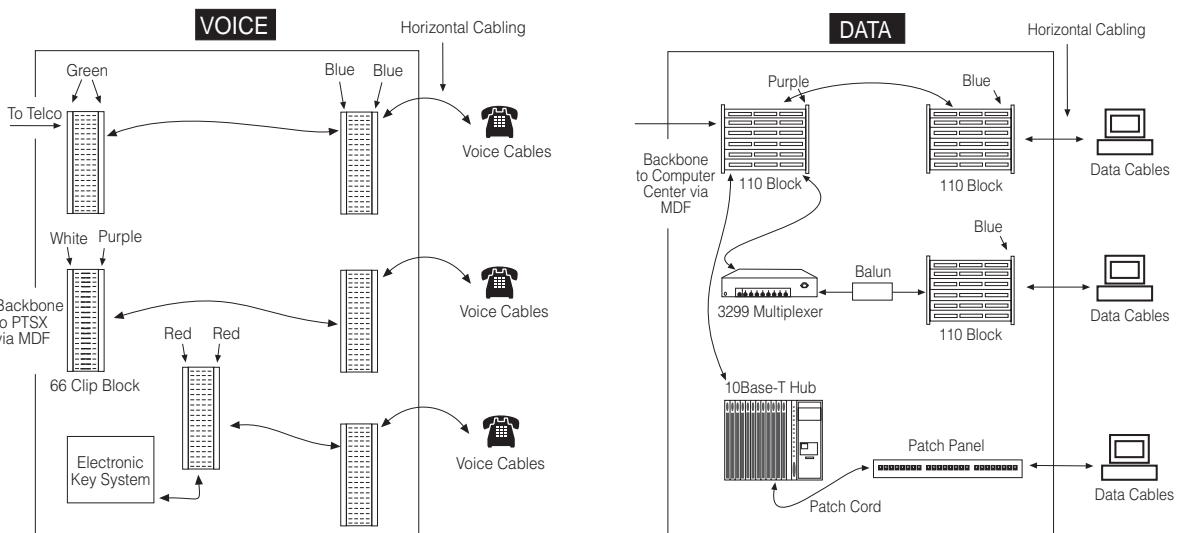

TABLE 3-5. Crossconnect Field Color Codes.

Crossconnect Field	Color
Backbone cable from main crossconnect	White
Backbone cable from intermediate crossconnect	Grey
Customer side of demarcation point	Green
Common equipment (PBXs, LANs)	Purple
Horizontal cable	Blue
Auxiliary circuits (alarms, etc.)	Yellow
Key Telephone	Red
Central Office Cable	Orange
Campus Cable	Brown

with more electronic equipment. Thus it is important to maintain sufficient space for cooling and heating, servicing, and cable management.

The following electronic equipment is often housed in the TC:

- 1) Key system
- 2) Small PBX
- 3) Multiplexer or hub
- 4) Security system
- 5) File or print servers

### 3.4.3 TC PATHWAYS

- **The TC will have conduits or raceways entering the TC for backbone and horizontal cables.**

## 3.5 CABLING SYSTEM ADMINISTRATION (COMPLIANCE WITH TIA-606)

To facilitate ongoing wiring system management and changes, wiring installations should be documented per the requirements of TIA-606. Proper wiring administration is a requirement of TIA-568-A.

**Wiring administration involves both the planning and documentation of each installation.** Over time, changes to even the most well-laid-out installation can (and often do) degrade into an installation that is almost impossible to administer. The accumulation of 'quick fixes', leftover disconnected equipment, and nonstandard installation changes often accumulate in closets, with the result that even simple changes are more difficult and time-consuming to make.

Good administration is every bit as important as making good connections to wires. The following is a basic checklist of administration practices. If local practices have been established, these should be discussed with the building owner or manager, and adhered to carefully.

### GENERAL TIPS ON WIRING ADMINISTRATION

- **Plan for change.** Allow sufficient space in closets and elsewhere to make the changes that are both inevitable and, in many cases, unforeseeable. Logically plan the points at which the system will be cross-connected such that each individual case can be efficiently dealt with, but unnecessary connections (which would degrade system performance) are not added. (This is particularly important for Category compliance.)
- **Avoid quick fixes.** Use standard wiring practices so that all connections can be easily found and identified. Cross-connections made in ceilings, for example, are not standard, and so will inevitably be forgotten and difficult to administer.
- **Use a consistent plan for documenting all wiring.** The plan may be simple or complex depending on the installation, but it must be complete, orderly, scrupulously maintained, and readily accessible. Finally, it should be decipherable by other installers.
- **Neatness is essential.** All wiring should be laid out neatly and consistently. Closets should be kept clean, with adequate room to work. Do not let old equipment, leftover materials, and miscellaneous items accumulate and impede full access to wiring and equipment in use.
- **Assure that all connections have adequate service loop for minor changes.**
- **Use a worksheet to document the installation** and indicate the length of cable runs to each room, the location of primary and secondary outlets (identified as such and in which order

they were run from the primary), the station numbers (phone numbers) of each access line (if known), and the wire color combinations for each line and the relationship between wire colors where colors have been converted at the distribution device, etcetera. Note any special circumstances, and leave a copy of the document near the distribution device for future reference.

- **Clearly label** all station wire at each end, and clearly indicate the marking scheme on the worksheet.
- **Maintain the relationship of pairs and lines** at the distribution device, and label the lines clearly if the distribution device does not have a clear marking scheme.

➡ **Continue to Book 4 for Fiber Optic Cabling System installation practices in compliance with TIA-568-A (Commercial Building Installations).**

## CATEGORY 5 UTP INSTALLATION—DO'S AND DON'TS GUIDE

In order for unshielded twisted-pair (UTP) cable (including Cat 5, Cat 5e and more advanced systems) to deliver high-speed performance, it is manufactured to very tight specifications. In order to maintain UTP cabling system performance after manufacture, proper handling is *essential*.

Damaging cable can greatly affect its ability to carry data at higher rates—and once damaged, is not always readily 'fixable'. Many common occurrences, like over-stretching or over-bending, can permanently stretch the

conductors or alter the insulation, thus affecting the transmission properties of the cable. For example, cable that has been kinked cannot just be straightened out and expected to provide the intended level of performance.

Thus proper installation is one of the most important keys to cabling system performance. By heeding the following installation tips, and avoiding common handling mistakes, there is much greater assurance that the cabling system will perform as planned.

### CABLE TENSION

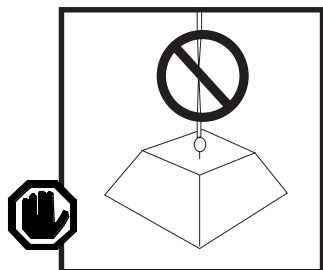

**DON'T** pull cable with excessive force, as this will alter the cable's insulation and transmission properties.

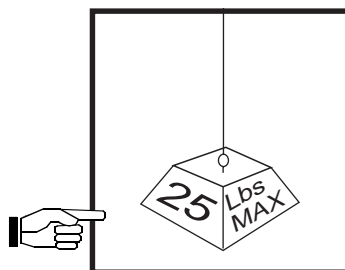

**DO** pull cable using less than 25 pounds of pull-force.

### UNROLLING CABLE



**DON'T** allow the cable to kink, knot or snag while pulling it off the spool or out of the box; deforming the pair-twist will alter the performance of the cable.

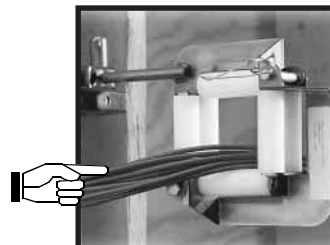
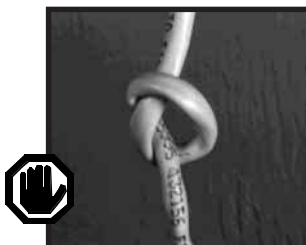

**DO** use a cable pulling accessory.

## CATEGORY 5 UTP INSTALLATION—DO'S AND DON'TS GUIDE

### RUNNING & SUPPORTING CABLE

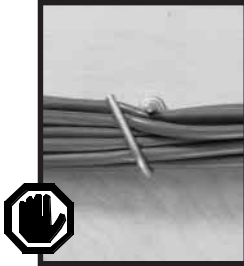

**DON'T** overstress cables by overloading...

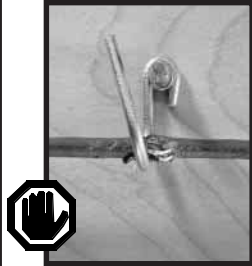

...and **DON'T** allow the cable hook to rip or fray the cable.

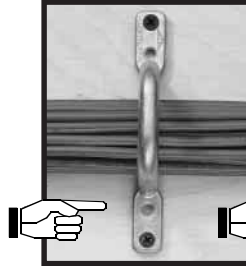

**DO** use j-hooks or similar devices designed to support cables.

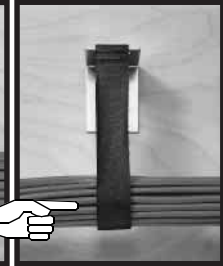
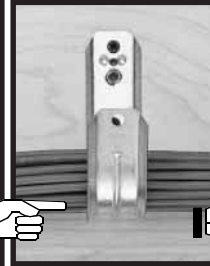

### RUNNING & SECURING CABLE

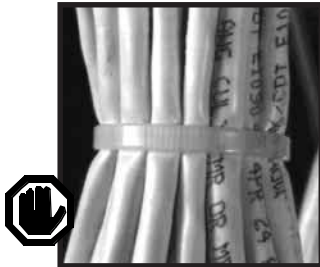

**DON'T** overstress cables by overtightening cable ties, especially to the point where crush-stress is visible.

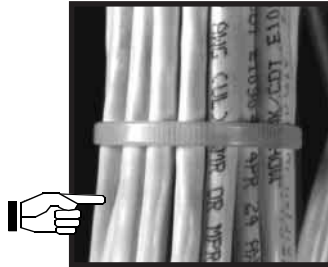

**DO** use tie wraps loosely on large bundles. (see also 'Using Tie-wraps')

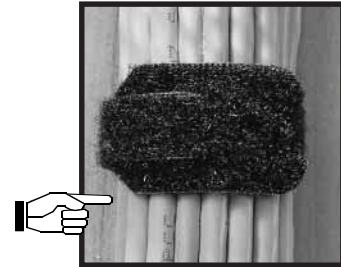

**DO** use Velcro® tie wraps to secure large bundles.

### USING WIRE CHANNELS

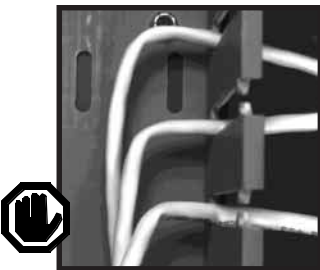

**DON'T** allow the cable to form right angles or sharp bends.

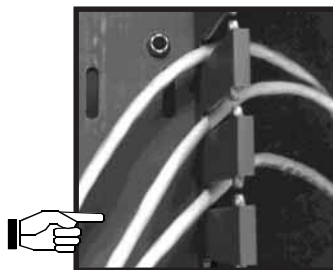

**DO** use sweeping bends.

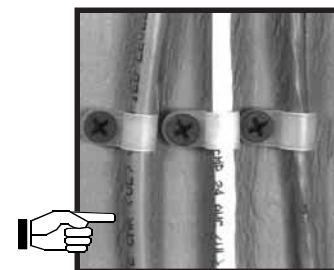

**DO** use cable clamps on individual runs.



## CATEGORY 5 UTP INSTALLATION—DO'S AND DON'TS GUIDE

### STAPLING CABLE

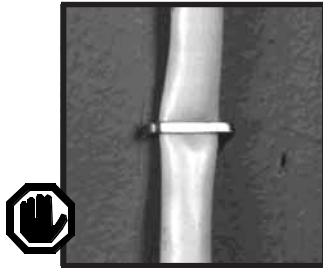

**DON'T** squish cables when securing them.

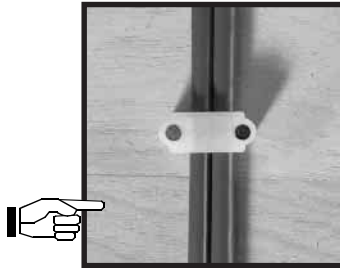

**DO** staple by hand, or use staplers with depth stops.

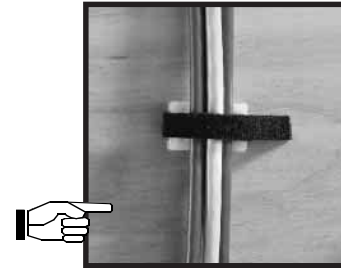

**DO** use Velcro® to keep cables from becoming over-cinched.

### USING TIE-WRAPPS

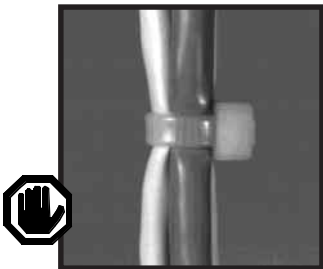

**DON'T** cinch the cables tightly, especially to the point where crush-stress is visible.

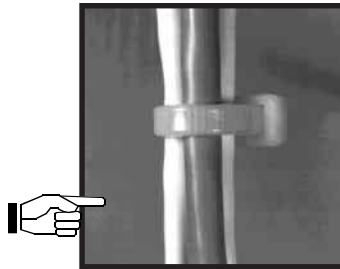

**DO** tie-wrap the bundle loosely.

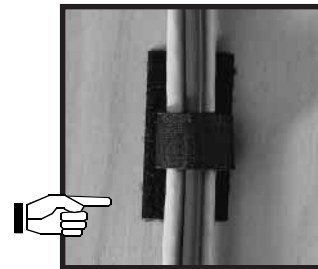

**DO** use Velcro® as a flexible and reusable alternative to plastic tie-wraps to keep bundles from cinching.

### REMOVING CABLE JACKET

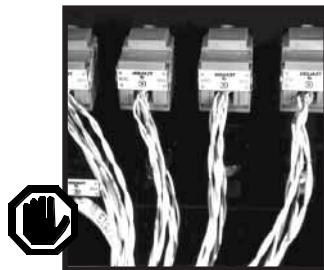

**DON'T** remove too much cable jacket.

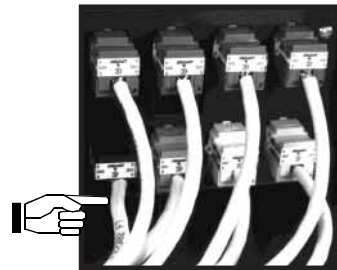

**DO** retain cable jacket as close to the termination point as possible.

## CATEGORY 5 UTP INSTALLATION—DO'S AND DON'TS GUIDE

### MAINTAINING PAIR TWISTS DURING TERMINATION

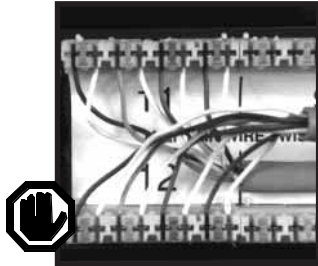

**DON'T** untwist the cable pairs more than 1/2 inch and **DON'T** strip cable jacket back any more than you need to.

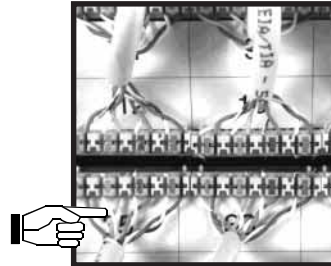

**DO** maintain pair twists to within 1/2 inch of the termination point, and the cable jacket is maintained as close to the terminations as possible.

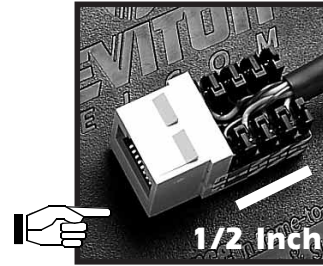

**1/2 Inch Guide:** The 110 Termination Deck on Leviton jacks is 1/2" long, making it easy to assure compliance with the TIA-568-A 1/2 inch maximum untwisting rule for Category 5 cable and less than 1/2 inch maximum for Category 5e and 6. Also, the center channel helps bring the wire right up to the terminations.

### TERMINATING ONTO 66 BLOCKS

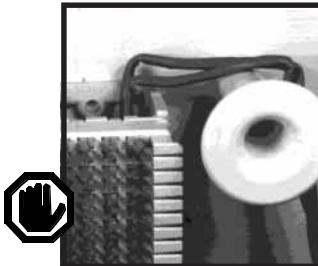

**DON'T** kink or twist cables sharply.

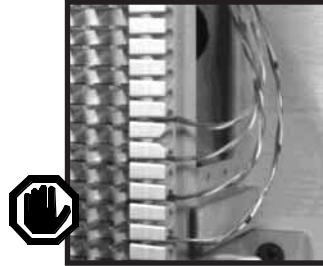

**DON'T** unstrip too much cable jacket.

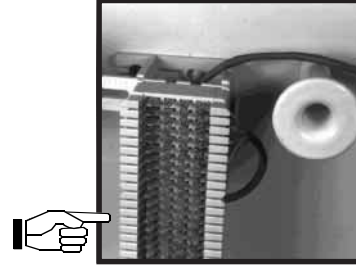

**DO** use cable management to avoid twisting or kinking.

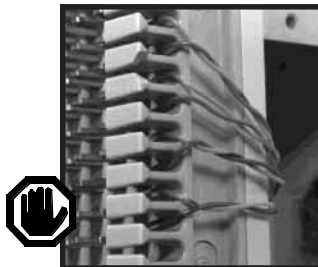

**DON'T** allow pairs to untwist more than the maximum allowed for the cable's Category rating:  
Above Category 5: <math>1/2</math>" max untwist  
Category 5: <math>1/2</math>" max. untwist  
Category 4: 1" max. untwist  
Category 3: 3" max. untwist

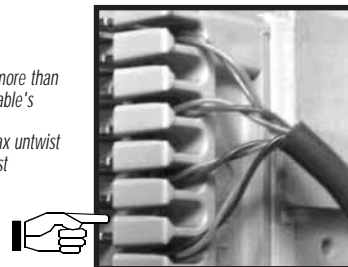

**DO** maintain pair twisting close to the termination point. Route individual pairs as shown to maximize pair twisting. (Also note that the cable jacket is maintained as close to the terminations as possible.)

### TERMINATING ONTO 110 BLOCKS

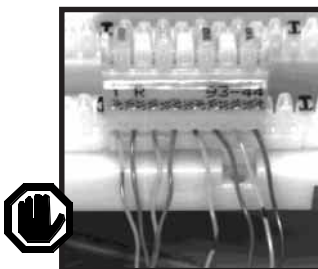

**DON'T** allow pairs to untwist more than the maximum allowed for the cable's Category rating:  
Above Category 5: <math>1/2</math>" max untwist  
Category 5: <math>1/2</math>" max. untwist  
Category 4: 1" max. untwist  
Category 3: 3" max. untwist

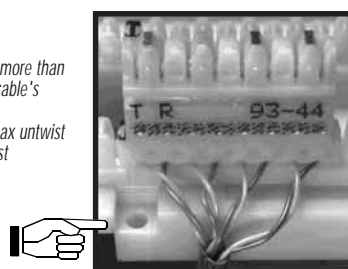

**DO** maintain pair twisting close to the termination point. (Also note that the cable jacket is maintained as close to the terminations as possible.)

## TESTING & TROUBLESHOOTING CATEGORY 5 WIRING FOR COMMERCIAL BUILDINGS

This section is intended to familiarize the reader on field testing requirements for Category 5 cabling systems, which have been defined by the TIA in their Technical Service Bulletin TSB-67, "Link Performance Transmission Specification For Field Testing of Unshielded Twisted Pair Cabling Systems". The document defines pass/fail criteria to ensure that the installed cabling is capable of supporting high speed LAN equipment.

The following section is based on TSB-67 and provides basic testing guidance. For more information, please read TSB-67 and consult test-unit instructions for the Category 5 field tester you use.

### 3T.1 OVERVIEW

#### 3T.1.1 HOW TESTING BENEFITS BOTH END-USERS AND INSTALLERS.

Category 5 cabling system certification verifies that no faults occurred during installation, and ensures that the system will perform to the end-user's requirements. This gives everyone peace of mind, and for the installer can help prevent later callbacks, or blame for problems which can be proven not due to installer workmanship.

However remember that while TSB-67 allows you to test all or part of a cable run to verify that it meets the TIA-568-A Category 5 limits, the connection of equipment will change how the network behaves; TSB-67 cannot guarantee how high-speed network equipment will work on or affect a tested cable run.

#### 3T.1.2 THE DIFFERENCE BETWEEN A CHANNEL AND A LINK

It is important to differentiate between the terms channel and link, because they describe two Category 5 certification tests. These tests cover the two instances in which cable would be tested, and they differ in how much of a horizontal cabling run they include for testing. The basic difference is that a channel includes patching or equipment cords, while a link does not (see Fig. 3T-1).

Separating the tests this way allows the contractor to verify that link and channel installations are performed correctly. This is very important information, as workmanship has a direct impact on system performance (see Fig. 3T-2). Initial test results also provide performance guidelines that are a valuable baseline reference for future testing.

The first test covers the *link* (also called *Basic Link*, *Contractor Link* or *Contractor Model*). The link is the permanent part of the cable run. A *link* is defined as up to 90 meters of horizontal cable; a telecommunications outlet; an optional transition connection close to the work area; and two connections at the cross-connect in the telecommunications closet (Fig. 3T-1). The total maximum length of equipment cords, patch cords and jumpers for the cable run is 10 meters.

A second round of testing can be done *after* the end-user has connected their patch cords and equipment cords. At this time the horizontal run is called the *channel* (or *User Model*). The channel test provides more comprehensive, end-to-end test coverage (although the Link test is actually

Fig. 3T-1. Channel and Link Test Configurations

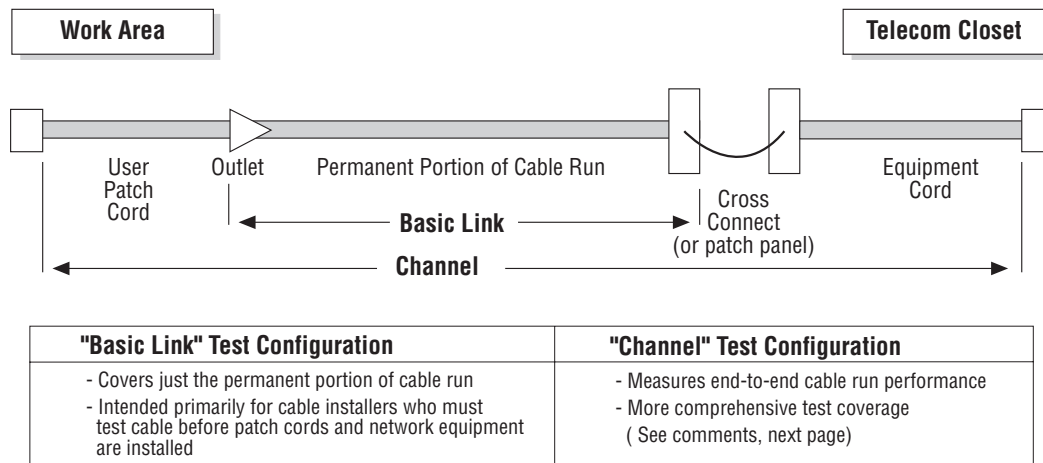

more stringent because it must allow for the later installation of patch cords).

**The Effects of Workmanship And Patch/Equipment Cordage Upon Cabling Performance.** Another reason why channel and link tests evolved has to do with quality of workmanship and materials. Channel performance is greatly affected by cable characteristics, connecting hardware, patch cords and cross-connect wiring, total number of connections, and the care with which they are installed and maintained (See Fig. 3T-2). You can go a long way toward preserving performance by simply choosing good quality components, and installing them with care and proper techniques.

**Link and Channel Pass/Fail limits.** Pass/Fail limits for attenuation and crosstalk (NEXT) differ for links and channels. Channel limits are the same as in the original TIA-568-A, but since there are fewer connectors in a link, link P/F limits have been defined and introduced in TSB-67.

**Specifications To Follow When Testing.** Use TSB-67 as your reference for Category 5 Test Specification Data. Prior to TSB-67, many installers used the laboratory test specifications in Annex E of TIA-568 to determine if a system performed to Category 5. Because these were not field test specs, Annex E is NOT to be used to test or verify installed systems.

**Fig. 3T-2.** Effects of Workmanship Upon Cabling System Performance

<b>Workmanship Impact on Channel Performance</b>	
<b>Condition</b>	<b>Next Performance Reduction</b>
Full Channel, Properly Installed	Benchmark
Cable flexed 1000 times	No change
Replace 2 ft Cat 5 patch cord with 2 ft Cat 3	8.0 dB
Replace 2 ft Cat 5 patch cord with 20 ft Cat 3	13.0 dB
Coiled Cable in a 6' circle, 2" dia. cross sect.	No change
Bundled and secured cable with ties (20lbs)	No change
Removed 1" of cable sheath at station end	1.2 dB
Removed 12" of cable sheath at station end	2.0 dB
Untwisted Pairs 1/2" at station end	1.5 dB
Untwisted Pairs 2" at station end	3.8 dB
Untwisted Pairs 6" at station end	11.6 dB
Bend cable around a 3" diameter	1.9 dB
Bend cable around a 1" diameter	2.1 dB
Kinked Cable	2.4 dB
Cable run in aluminum conduit	No change

**Importance of Marking Cat 5 Cable Prior to Installation.** It is very important to mark Category 5 cable ends prior to pulling them to outlets, as *conventional locating equipment (toner and probe) does not work for identifying the run along the length of the cable.* This is because Category 5 cable works so well at canceling out external signals, that the tone cannot be detected through the cable jacket. A Cat 5 cable tester will perform the task, but ideally this step will be saved by properly marking the cable before installation.

**Test Cable Immediately After Cable Pull-In.** Installation of cabling systems typically occurs in four basic stages:

- 1) Identifying/marketing the cable ends.
- 2) Pulling the cables.
- 3) Punching down the cables on the crossconnects and the outlets.
- 4) Installing and crossconnecting the equipment.

The cabling system should be verified immediately after or during the third stage. This simplifies subsequent troubleshooting if problems arise after the equipment is installed, by ruling out the cabling system as a probable cause.

**Use testing and troubleshooting equipment specifically designed for Category 5 network installation and repair—and read the instructions which come with the unit.** *Experience has shown that when substitute test equipment is used, the procedures will take longer, be less reliable in finding the fault, and often will find only part of the problem.*

➔ **For a Manufacturer Listing of Category 5 Cable Testers, refer to page 2-23 of Book 2T.**

## 3T.2 TESTING

### 3T.2.1 REQUIRED TESTS FOR CATEGORY 5 CABLE.

The primary field test parameters are Wire Map, Length, Attenuation, NEXT, and Propagation delay.

**Test 1. The wire map test** is intended to identify installation wiring errors. (Correct connectivity is defined in TIA-568-A section 10.4.5.) Any incorrect pairing must be reterminated in the correct fashion.

**Test 2. The length test** verifies that lengths fall within TIA-568-A specified maximums. Physical length is defined as the sum of the physical length of the cables between the two end points in the link. Physical length may be derived from either physically measuring the length of the cables, as determined from the length markings on the cable or estimated from the electrical length measurement. The length of the longest pair shall be reported.

The maximum length of the basic link shall be 94 meters (including test equipment cords). The maximum length of the channel shall be 100 meters, including equipment cords/patch cords.

**Test 3. The Attenuation test** is a measure of signal loss from one end of the link to the other. You must test all wire pairs within a cable, and compare the worst performance reading to the allowable attenuation. The worst-case pair must not perform worse than the TSB-67 specified attenuation value.

**Test 4. NEXT** (Near-End Crosstalk) is a measure of signal coupling from one pair to another within a UTP cable link. A balanced input signal is applied to a disturbing pair at the near end of the connector, while the induced signal on the disturbed pair is measured at the near-end. The resulting NEXT loss must be better than the worst case values given in TSB-67. All pair combinations must be measured, from both ends.

Field tests of NEXT shall be done at both ends of the cable to ensure that far-end connections are checked for compliance.

**Test 5. Propagation Delay.** This test measures the time it takes for a signal to travel from one point to another. The worst case (longest delay) shall be reported.

Note that having a non-TIA-568-A system pass these tests does not make it TIA-568-A compliant.

**Test 6. Power Sum.** While not a standardized field test, Power Sum NEXT is a standardized measurement for 25-pair Cat 5 cables. Power Sum NEXT is a measure of the ability of many pairs to operate within the same sheath without interfering with one another—such as in 25-pair cable.

Power Sum can also be applied to 4-pair cable as a measure of its ability to successfully carry multi-pair transmissions.

### 3T.2.2 GENERAL TEST RULES

- No cabling or components shall be moved during the tests.
- In addition to pass/fail indications, the actual measured values (at whatever frequency taken) should be recorded in the administration system for use in future configuration or analyses of the premises network.
- NEXT must be measured from both ends of a cable run.
- Reconfiguration may require re-testing.
- Qualified adapter cords shall be used to attach the test instruments to the link under inspection.
- In a *channel* (see definition), end-user patch cords shall be tested in place. End-user patch cords may be verified by inserting the user cords in the link under test at the cross-connect.
- Allowance is made for 10 meters of equipment and patch cordage, and jumpers for the channel. (5 meters on each end is assumed.)
- UTP test leads and associated connecting hardware to connect between the test equipment and the link under test, shall be 0.5 mm (24 AWG) and shall be taken from cable that meets or exceeds the requirements for Category 5 cable specified in TIA-568-A.
- Coaxial cable assemblies between network analyzer and baluns should be as short as possible, preferably not exceeding 0.6 m (24 in) each.
- 100Ω four-pair Category 3 or 5 UTP cable may be tested while still on the reel, if the length is under 100 meters.
- The field tester must meet the TSB-67 accuracy requirements for Level 1 or 2 (see Section 3T.3).
- If a run barely passes (the result is within the tester's accuracy limit), the data must carry a warning (such as an asterisk) to indicate that the result was marginal.



## 3T.3 TOOLS

**About Category 5 Test Sets.** For Category 3 and 4 UTP, 20 MHz 150 $\Omega$  STP and optical fiber, portable test sets are available to verify link performance. But for Category 5 UTP and Extended 150 $\Omega$  STP, test sets to verify performance to the upper limit of the cabling system characterization are defined by TSB-67.

No standard or TSB specifies or requires Power Sum testing methodology or limits. However, some manufacturers offer a Power Sum test capability in their field test equipment.

**Tester Accuracy Levels I and II.** Testers have been categorized by TSB-67 into two levels of accuracy. Level I testers are those available before TSB-67 was published, and are not as accurate as post-standard field testers are. Level II testers are closer to laboratory grade and thus more accurate, so they pass fewer 'bad' runs and fail fewer 'good' runs.

**Parameters That Category 5 Testers Must Be Able To Test For.** The TSB-67 testing specification requires the following tests: length for all pairs of an installed link; attenuation; NEXT; and the delay on all pairs of an installed link.

**Tester Must-Have Features.** A Category 5 Tester must be capable of measuring all required data (see above), and have a 310 meter range to allow for approximate measurements of available cable on spools. The unit should also come with manufacturer's information on how to interpret data with the device.

**Tester Nice-to-Have Features.** Some features which are nice to have in a test instrument are: LED or LCD readout; data storage; auto test; and ease of use. Also, the faster the better. For example, on a 1000-workstation job, having a 90-second tester takes half the time of a 3-minute tester—or 25 hours instead of 50 hours of labor.

## HORIZONTAL INSTALLATION PRACTICES FOR FIBER OPTIC CABLING SYSTEMS

**IMPORTANT NOTE:** The following information is provided for reference only and is not intended to replace formal training or instruction in fiber optic installation.

For information and many illustrations in this section Leviton wishes to thank *The Light Brigade*, a nationally-renowned specialist in optical fiber training, design and installation: Phone (425) 251-1240, Fax (425) 251-1245.

### 4.1 OVERVIEW

#### 4.1.1 FIBER OPTIC TECHNOLOGY

Fiber optics is a technology in which electrical video/data/voice signals are converted into light, and then the light is beamed through an optical fiber to transport the information from one point to another. The fiber is a thin filament of glass through which the light travels.

Because one optical fiber can do the job of hundreds of copper cables, optical fiber is increasingly being used for communications signaling systems. Applications such as FDDI, ATM, and broadband video are currently optical fiber based. Also, fiber provides many advantages over copper wiring in both residential and commercial applications.

**Fig. 4-1.** Unlike Copper Cabling, Fiber Is Immune to EMI (electromagnetic interference).

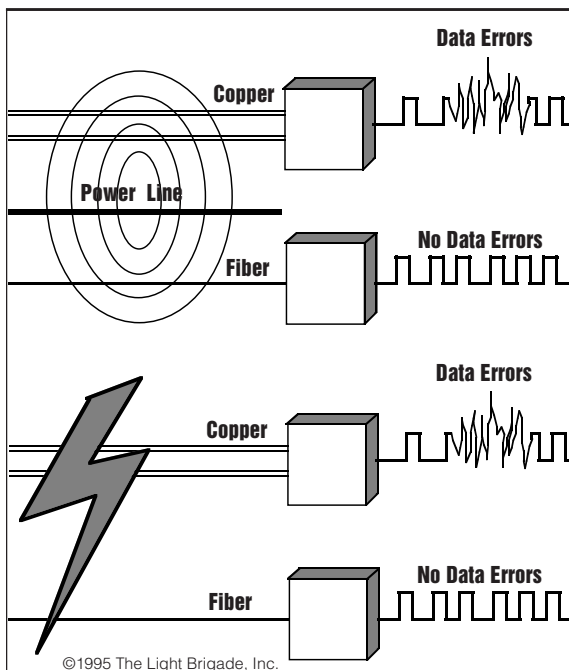

#### 4.1.2 FIBER OPTICS ADVANTAGES

Benefits of fiber over copper include the following:

*Noise immunity:* Copper wire systems require shielding to prevent electromagnetic (EMI) induction or 'pick up', but fiber optic cable is a dielectric and thus not affected by these factors (see Figure 4-1).

*Low attenuation (signal loss).* Current singlemode fibers have losses as low as .2 dB per kilometer. Multimode losses can be less than 1 dB per kilometer. This creates opportunities for longer spans without the use of repeaters. (For information on singlemode and multimode cables, see Section 4.2.2.)

*No possibility of short circuits* since the fiber is glass and does not carry electrical current, radiate energy, or produce heat or sparks.

*Greater transmission security,* because the fiber does not radiate electromagnetic pulses, radiation, or other energy that can be detected. It is not possible to tap into fiber optic cable without creating a loss that is easily detected at the receiver.

*Fiber is becoming more price-competitive to copper.* In fact, running fiber to the desk is only about 10% more than the cost of copper. Thus it is becoming easier to justify fiber, especially in light of its availability and impressive capability.

*Fiber carries more data, much faster and in less space.* The current state-of-the-art optical fiber system is known as SONET/SDH, level OC 192. It uses a singlemode fiber that transmits 129,024 voice channels at 9.953 gigabits (billion bits) per second—which is more than 120,000 times the information of electronic signals over copper wire. Besides having plenty of capacity (*bandwidth*) for current trends, fiber's large bandwidth also leaves room for capabilities beyond current technologies. Also, fiber takes up much less space and is more lightweight than copper cable of comparable performance, eliminating crowded conduits.

*Fiber is a mature, established, standardized industry.* While copper applications keep pushing the limits of UTP (and thus constantly redefining and revising its relatively young TIA standards), the fiber industry has been around for decades and has long since established its standards and installation practices, including testing.

### 4.1.3 FIBER OPTICS DISADVANTAGES

Time is sometimes an enemy to fiber installations because fiber takes somewhat longer to connectorize than copper, and requires skilled labor and specialized tools. However, with new termination technologies, the time it takes to terminate fiber has lessened and can often be almost equal to copper.

Until recently fiber's main disadvantage has been a much higher price. Lately, however, increased competition, larger manufacturing volumes and standardization of common products have eroded the price to a margin that is very competitive with copper.

## 4.2 FIBER CABLE CONSTRUCTION

An optical fiber is composed of three united layers. In the center is the *core* filament of glass which is used to transmit the light signals. This is surrounded by *cladding* to keep the optical signal within the core. Covering these is a plastic *inner coating* which protects the glass from abrasion and adds strength. These layers make up what is called *the fiber* (Fig. 4-2).

Note that cores can consist of plastic or glass, as can the cladding. Most common fibers used today have a silica glass core with a silica glass cladding; however the use of plastic fibers for short distance links is increasing.

To make the fiber into fiber optic cable, certain materials are added. A variety of buffers, or outer coatings, are added by the cable manufacturer. Common fiber coating sizes are 250 and 900 microns. The 250 micron size is typically used in outdoor cables, while the 900 micron size is typically used for indoor cable designs.

Kevlar®, a very strong aramid yarn made by DuPont, is used in cables as a strength member to both protect the fiber and facilitate pulling the cable through ducts or building riser sleeves. For installations requiring more durable cables, fiber glass and steel center strength members are also available.

### 4.2.1 CABLE TYPES

While all fiber cables share the same basic construction, there are multimode versions which differ in their proportion of core to inner cladding. This proportion is designated in the cable name by the two numbers separated by a slash (see Fig. 4-3). The TIA-568-A standard recognizes two fibers: the 62.5/125µm for multimode, and the 9/125µm for singlemode applications. Other types are considered alternate fibers acceptable for installation.

Fig. 4-2. Optical Fibers.

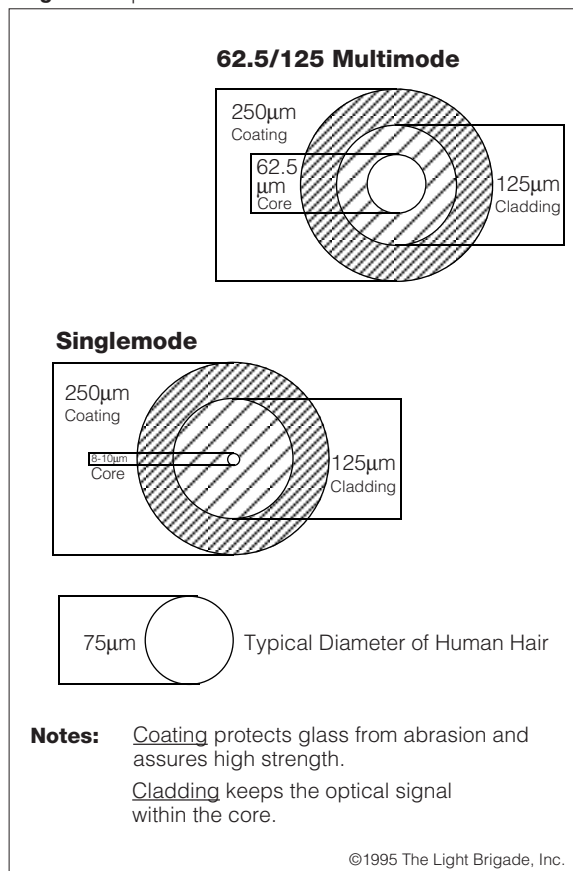

### 4.2.2 Singlemode and Multimode

Optical fibers can be either singlemode or multimode. A mode is the light path in the optical fiber.

A singlemode fiber has a small core that allows only one light path, resulting in a very focused, high-quality signal. However the core is so small that it usually requires a laser source to 'launch' light into the cable—and laser sources are usually more expensive than the LED sources used for multimode fibers.

A multimode fiber has a larger core diameter. The larger the core, the more modes it can accept. In other words, more light can be launched into a multimode core. However the increase in the amount of modes actually decreases the optical bandwidth of a fiber, as the signal is less concentrated. Multimode fibers are very good at coupling light from inexpensive LEDs.

### 4.2.3 DISTRIBUTION AND BREAKOUT STYLES

Distribution cables have smaller diameters and tend to work better in confined spaces. They are typically used in vertical backbone.

*Breakout style cables* tend to be used for horizontal runs because they have internal Kevlar® strength members which allow for direct connectorization onto the cable.

### 4.2.4 LOOSE-TUBE AND TIGHT-TUBE STYLES

A plastic buffer tube surrounds the fiber, providing mechanical isolation to help protect it from crushing and impact loads, and to some extent from the macro bending induced during cabling operations. Buffer tubes can be either tight-tube or loose-tube/gel-filled.

In *tight-tube* cable construction, the buffer tube is an extrusion of plastic applied directly over the basic fiber coating. This type is used for indoor applications.

*Loose-tube* is a cable construction where the buffer tube's inner diameter is much larger than the fiber itself, leaving a gap between the tube and the fiber. This extra space is often filled with a gel to cushion the fiber, further isolating it from any exterior mechanical forces acting on the cable, and preventing moisture intrusion. This cable structure handles stress and environmental changes better than indoor-rated cable, and is primarily used for outdoor applications.

### 4.2.5 PERFORMANCE CRITERIA FOR COMPARING CABLES FROM DIFFERENT MANUFACTURERS

In the end, the performance characteristics of fiber cables vary depending upon the materials used and the

process of manufacturing. The following criteria are useful in verifying performance when choosing a fiber cable:

- **Attenuation.** A lower number = less signal loss.
- **Bandwidth.** A higher number = more capacity.
- **Numerical aperture (N.A).** A lower number = more bandwidth. But note that less power will be coupled into the fiber.
- **Core size**—Follow these three rules of thumb:
  - the smaller the core, the lower the attenuation.
  - the smaller the core, the higher the bandwidth.
  - the smaller the core, the lower the cable cost.
 However as the core size decreases, the price of the required connectors and equipment increases.
- **Environmental factors** (temperature ratings, tensile stress, bend radius requirements, etc.).

## 4.3 OPTICAL FIBER TRANSMISSION

Starting with the source of a transmission signal, when a data signal travels through a fiber optic system, it first goes into an *Optical Electrical Transducer* which converts the electrical signal to light pulses. Note: on schematic drawings this transducer end is often designated the *E/O* (Electrical/Optical) device.

The optical fiber carries the signal from source to the receiving optical electrical transducer, and then to the receiver. Along the way, it will be routed through various jumpers, crossconnect panels and distribution panels located in various sites throughout a building or complex, until it gets to the receiver (Fig. 4-3).

The signal may also pass through a *Multiplexer (MUX)*, an electronic device which allows two or more signals to pass over one communications circuit. The MUX

Fig. 4-3. The Signal Path Through a Fiber optic System.

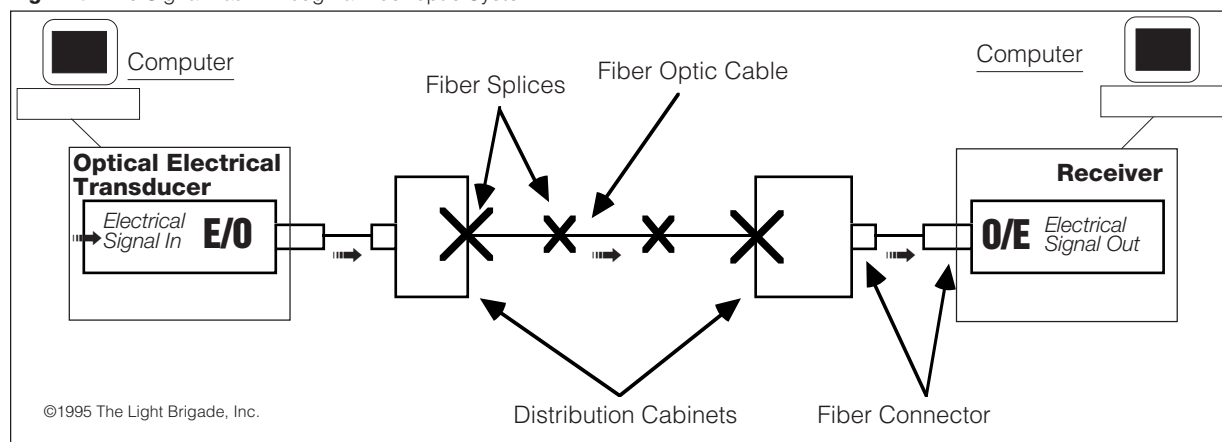

©1995 The Light Brigade, Inc.

combines multiple signals into one bit stream, and converts Analog signals to Digital, and vice-versa.

At the receiving end, an *Optical-Electrical Transducer* converts the light pulses back into electronic data signals. (In a schematic the Receiver end is called the O/E, for Optical/Electrical).

**TIP:** To minimize core and numerical aperture mismatch, use the same fiber manufacturer for transmitter-to-receiver cable segments.

## 4.4 INSTALLING OPTICAL CABLE

### 4.4.1 FIBER SYSTEM TOPOLOGY

The horizontal topology for fiber is the same as for copper—a star topology (see Fig. 4-4). Cable is pulled from the main cross-connect (MC) to the intermediate cross-connect (IC), and from the IC to the horizontal cross-connect (HC).

From the HC, home run cables are placed to the workstation outlet (WO). See Figure 4-4 for maximum distances.

Fig. 4-4. Fiber System Topology

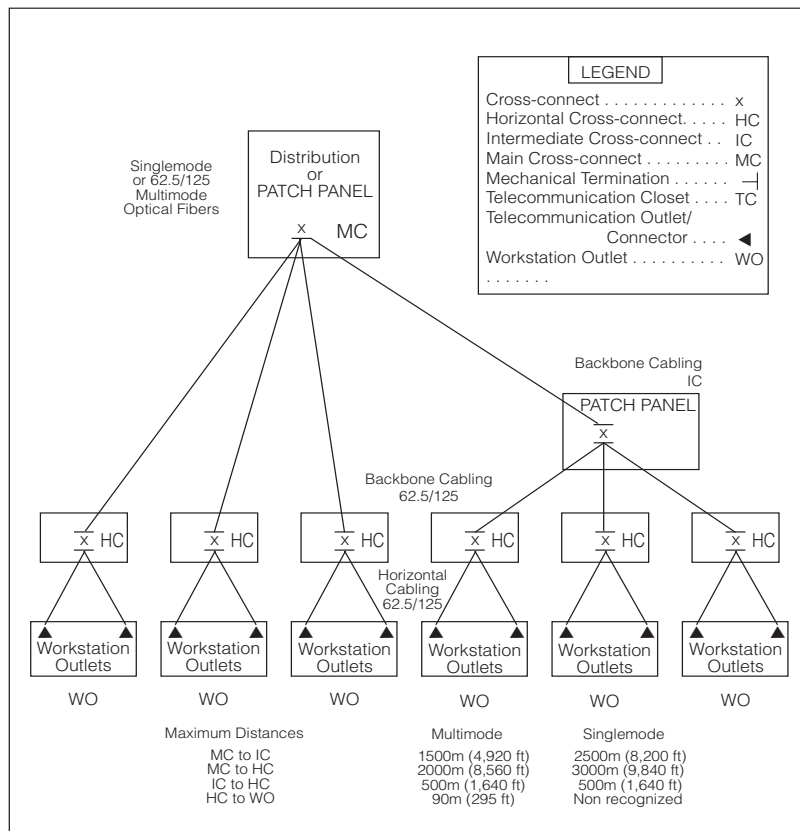

### 4.4.2 PRESERVING SIGNAL DIRECTION

The TIA building wiring committees recommend that each fiber optic cable—horizontal, backbone or patch cord—be reversed for one end to the other. In other words, side one of the Transmit end will be coded as the Receive side on the other end. (See Figure 4-5.) The same applies to connectors. If everything is reversed in this manner, then the signal direction is preserved no matter how many connections are made.

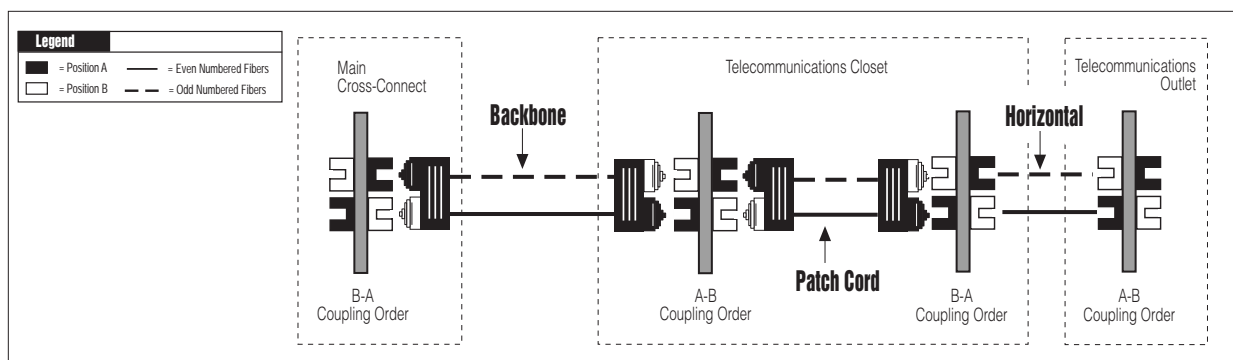

Fig. 4-5. For technical information, call 1 (800) 722-2082 • For product information, call 1 (800) 922-6229 • website: www.levitontelcom.com • e-mail: info@levitontelcom.com



## 4.5 HANDLING FIBER OPTIC CABLE

### 4.5.1 REDUCING LOSS BY PROPER HANDLING

Like all cable, fiber optic cable must be handled properly to minimize any installation-induced signal losses (the attenuation, or deterioration, of the light signal during transmission).

Of course some losses are *intrinsic*, or out of the installer's control; these include effects from internal absorption, scattering, fiber core variations, and microbends. But *extrinsic* losses related to workmanship can and should be controlled; these include connections, splices, end finishes, microbends and macrobends.

Installing optical cables can usually be done with a minimal amount of effort if certain basic guidelines are followed.

### 4.5.2 GENERAL INSTALLATION TIPS

- Always follow the manufacturer's guidelines for minimum bend radius and tension. Failure to do so may result in high attenuation and possible damage to the cable and fiber. Guidelines are normally supplied with the cable manufacturer specification sheets. If the bend radius specifications are unknown, the industry de facto standard is to maintain a minimum radius of 20X the diameter of the cable.
- Manufacturers may give two specifications for both radius and tension. These are called *Static and Dynamic specifications*. "Dynamic" is the specification during the cable installation or while cable is under load, and "Static" is the specification for after installation is complete.
- If using tie-wraps, remember not to distort the shape of the cable, as this adds pressure onto the optical fibers.
- Install cables in a sequence that applies the least amount of strain on the cable.
- Identify fiber optic cable at all likely access points (ceiling access, etc.).
- Sharp bends increase cable tension, so it is best to install cable in sequences that minimize stress.
- Use sheaths and cable guides to maintain recommended cable bend radius.\*
- Monitor tension, and maintain racking bend radius.\*

- Protect exposed cables from vehicular and public traffic.
- Prior to installation, double-check actual fiber count.
- Always follow engineering and construction placement and route plans.
- Always follow National Electrical Code guidelines, as well as local and state codes.
- Maintain good communications between installation personnel.
- When installing loose-tube cables, use a silicone injection or sealer to prevent gel migration.
- For underground installation, center-pull long cables (see Section 4.5.3.). Store excess cable in vaults/manholes, and identify optical cables with markers.
- Aerial installation: Use proper hardware matching cable, span and tension requirements. Use correct cable jacket.
- Buried Cable Installations: Identify cable locations with surface markers. Anticipate obstructions.

\*Appropriate values for the cable being used are in the manufacturer's cable specs.

### 4.5.3 PULLING FIBER LONG DISTANCES

When pulling fiber over long distances or lots of bends, use the Center Pulling technique:

1. Pull longest section into assigned duct. For long pulls, use a mid-point to evenly distribute the pulling length and tension.
2. From mid point, pull cable into conduit from shipping reel.
3. Remove remainder of cable from shipping reel by hand, and carefully lay into figure-eight loops one upon another.
4. Hand-feed the end of the cable into the conduit and continue pulling. Communication is necessary to assure that no damage occurs to the fiber.

For extremely long pulls, the cable can be removed at a manhole further down the installation route. Figure-eight or zigzag the cable while the pulling equipment is moved to the next manhole site.

Remember, optical cables are lightweight and very flexible, but take care not to exceed their flexibility by physical abuse of the cable.

Following these guidelines should help to make the cable installation uneventful and successful.

## 4.6 FIBER OPTIC CABLE TERMINATION

Once the fiber cable runs are in, they are ready to be terminated. Fiber optic connectors offer a mechanical means to terminate optical fibers to other fibers and to active devices, thereby connecting O/E Transducers, receivers and cables into working links.

Connectors are terminated onto the fiber via splicing or connectorizing. To connectorize, a connector is attached to the end of a raw fiber. Connectors can be plugged in and out of patch panels, or station outlets.

In splicing, two bare fibers are joined together with a mechanical or fusion splice. A splice is a permanent joining method, used either to connect two cable runs together to make the run longer, or to add a pigtail connector onto the cable. A pigtail is a short piece of cable with a connector factory-attached to one end. Because of the great potential for misalignment, most singlemode terminations are factory-made onto pigtails.

The TIA-568-A standard does allow for fusion or mechanical splicing methods using pigtails, allowing for a maximum loss of .3 dB.

A general rule of thumb is that singlemode fibers are spliced, and multimode fibers are connectorized. In most multimode applications, cable will be directly terminated with a connector.

### 4.6.1 PREPARING FIBERS FOR SPLICING OR CONNECTORIZATION

To minimize the optical power loss across the intended fiber mating, certain conditions must be met. First, the fiber ends must be optically flat and smooth. Second, the end-to-end presentation of both fibers must align and the gap (air space) be minimized.

Reflectivity must especially be minimized in high speed digital systems and analog video systems incorporating laser sources, where the connectorized fiber end face can become a highly reflective surface. To prevent these large reflections from interfering with system performance, newer types of optical finishing techniques have been developed to reduce reflections.

For these applications, it is typical to use pigtails with pre-terminated factory polishes designed to reduce reflection. These should be fusion spliced to the cable, and housed in a splice tray incorporated into a patch panel (see distribution panel, Fig. 4-11)

**Fig. 4-6.** Remove Protective Jackets and Buffers To Prepare an Optical Fiber for Splicing or Connectorization

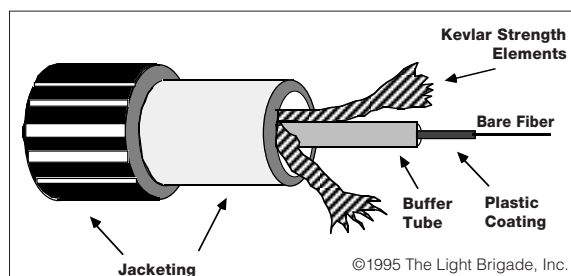

1. Remove the cable's protective jackets and buffers to allow access to the optical fiber.

Figure 4-6 shows the outer jacket and inner jackets are removed, exposing the Kevlar strength member, the buffer tube and the fiber. The fiber still has protective coatings which will also have to be removed. Standard cable strippers can be used to remove the outer jackets. Make sure the blades or cutting members are not damaging the buffer tubes.

The Kevlar® can be trimmed using scissors or Kevlar cutters. The amount removed can vary depending upon the design of the strength member of the cable. If the cable does not incorporate a strength member, the Kevlar® can be used as one.

2. The buffer tubes, like the outer jackets, can be removed by mechanical stripping tools. Use care not to kink or damage the internal coated fibers.
3. Once the coated fiber is exposed, remove the protective coatings to start the actual fiber splicing. Most coated fibers can be stripped using mechanical or chemical methods. Take care to use tools and procedures that will not damage the fibers.
4. After the coating is removed, clean the fiber with isopropyl alcohol to assure the fiber is clean, as contaminants on the fiber wall can cause the fiber to mis-align itself in the alignment fixture.

The fiber is now ready to be spliced or connectorized.

### 4.6.2 SPLICING

There are two types of splicing: fusion and mechanical. Fusion splicing is the joining and fusing of two fibers by placing them between two electrodes, and discharging an electric arc over the fibers. This splice technique is non-reflective. In mechanical splicing, the optical glass fibers are glued or mechanically gripped in place but not fused (melted) together.

Singlemode plugs are usually spliced to the fiber cable. When terminating, a great deal of care must be taken to align and center the core of the fiber. To get the optimum alignment, usually the fiber is sized to the outside diameter (O.D.) of the cladding (usually 125 +/- 1 micron), its core (9 +/- 1 micron), and the inside diameter (I.D.) of the connector ferrule (the component of a fiber optic connection that holds a fiber in place and aids in its alignment).

To avoid the great potential for misalignment, most singlemode terminations are factory-made onto pigtailed and then spliced via splice trays to the cable. In addition, low reflection polishes (such as PC, SPC and APC) must be performed in controlled manufacturing environments to maintain low loss and reflection levels.

### 4.6.3 BASIC CONNECTORIZING

The connectorizing process may vary with connector style and manufacturer, but generally all follow the same basic procedure (Figure 4-7).

Through the years, many techniques have been developed to improve on both the performance and the installation time to install fiber optic connectors. Each technique has its own advantages and disadvantages for users. Also, the installed cost is different for each one, depending on the component cost and level of skill required. The most common techniques are listed below.

- **Epoxy** is the most common of connectorization techniques. This method uses either heat-cure epoxy or an anaerobic epoxy to cure the fiber into the ferrule. After curing, the fiber is scribed and polished to a fine flat end surface. Several new connector types have the epoxy pre-loaded into the connector. Regarding installed cost, the parts for this method are the least expensive, but labor is more intensive than other techniques.
- **Cleave and Crimp** uses a pre-loaded fiber stub into the ferrule, allowing the user to prepare the fiber and jacket and then cleave the fiber to a pre-established length. The fiber is then inserted into the plug and crimped into place. This method requires the least skill on the part of the installer, but uses more expensive components.
- **Ultra Violet (UV) Adhesive** is similar to the epoxy technique, with the exception that the fiber is bonded via a UV adhesive and the use of a UV source such as a UV lamp or sunlight to cure the epoxy.
- **Epoxyless** are new no-epoxy connectors which use a unique body technique where the fiber and cable are crimped to the plug body. The plug is then

Fig. 4-7. Basic Connectorizing Steps.

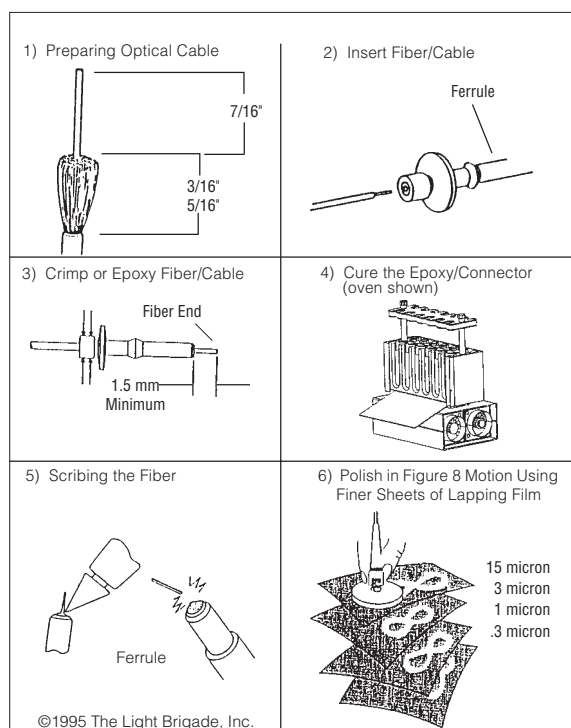

mounted into a tool which forces a plunger forward, forcing a resilient sphere to provide a compression fit over the fiber. The plug is then scribed and polished.

## 4.7 CONNECTORS

The primary task of a fiber optic connector is to minimize the optical loss across the interface of the coupled fibers. This loss is expressed in decibels (dB). High performance connectors are classified (and required by TIA-568-A) as those with less than .75 dB of loss. Losses occur from inexact end-to-end mating of the fibers, and the surface condition of fiber ends.

Secondly, the fiber optic connector is to provide mechanical and environmental protection and stability to the mated junction. And thirdly, the connector design should permit rapid and uncomplicated termination of a cable in a field setting.

An ideal connector would encompass the following features:

- Utilize a fiber alignment scheme yielding low loss;
- Be physically small;
- Be of rugged construction;
- Be easily field terminated;\*

- Be field repairable;\*
- Have good thermal characteristics;
- Offer excellent fiber/cable strain relief;
- Be of moderate cost;
- Be compatible with standard tooling and fiber cables.

\*(Factory-terminated cable assemblies provide users with the choice to field connectorize or to splice pigtail assemblies using fusion or mechanical splices).

#### 4.7.1 CONNECTORS RECOGNIZED BY TIA-568-A

Two connector systems are most prevalent today: the SC (Fig. 4-8) and the ST (Fig. 4-9). Both are excellent optical fiber connector systems. The TIA committees on building wiring have called out the SC as the connector of choice for new installations. But since the ST has a very large installed base in North America and Europe, it is allowed to remain in, or be added to, buildings and organizations which have an installed base of ST connectors.

The SC is a push-pull connector standardized by the ISO/IEC in 1992, when it was recognized as the preferred optical fiber connector for new installations in commercial buildings. The SC connector has since been recognized as the connector standard in the ANSI X3T9.3 Fiber Channel, ANSI X3T9.5 Low Cost FDDI, Broadband ISDN T1E1 (ATM) and by the TIA-568-A standards.

The SC is available as a simplex or duplex connector. It is keyed to prevent cross-mating, and uses a push-pull design to mate and unmate. The standard recommends it be color-coded beige for multimode, and blue for singlemode, but note that having these colors is not necessary for compliance.

Fig. 4-8. SC Fiber Connectors

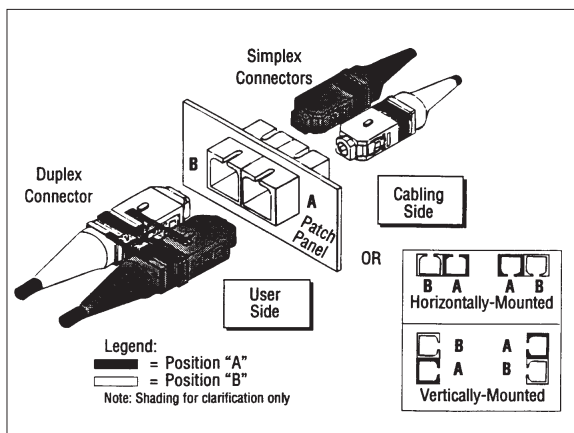

ST Connectors (BFOC/2.5): The de facto standard connector of the late 1980's and early 1990s, this bayonet connector style (uses a push/turn motion to attach to its mating sleeve) has been officially recognized by only one standard: IEEE 10BaseF. It is available in two versions, the ST and STII; both use a 2.5mm ferrule which is keyed.

Fig. 4-9. ST Fiber Connectors

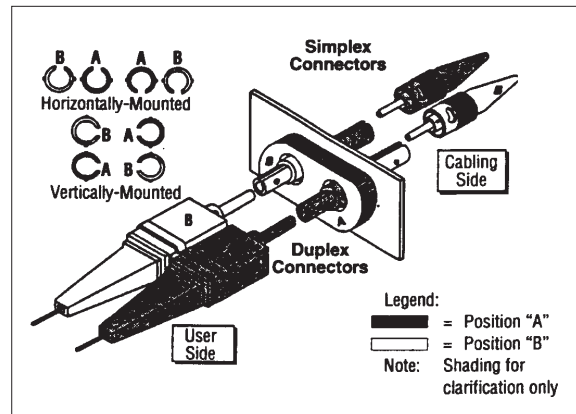

With the SC connector now preferred by most new standards, including the TIA-568-A Commercial Building Wiring Standard, the use of the ST may decline except in pre-existing installations where its use is "grandfathered".

#### 4.7.2 HYBRID CONNECTORS

Because of the evolution from ST to SC connectors, hybrid solutions (jumpers or adaptors) are coming on the market. These provide a path for current users (and manufacturers of network equipment) to migrate from the ST to the SC.

#### 4.7.3 OTHER CONNECTORS - MULTIMODE

The following connector styles are not recognized by the TIA-568-A standard but are included here for your information in case you run across them in your work, or need one for a particular application (such as the FDDI connector for FDDI applications).

The FDDI connector (also called MIC or FSD) was established in 1986 as the ANSI-approved interface for the Fiber Distributed Data Interface (FDDI). The FDDI connector has two 2.5mm ferrules in a keyed plug. External keys allow for system topologies such as ring and star, preventing cross-mating from occurring. Key selection is very important in the design and construction

of both the Ring and Star topologies, for them to comply with the proper topology requirements.

Two styles of sleeves (receptacles) allow for FDDI-to-FDDI connections, or hybrid ST-to-FDDI connections at patch panel interfaces.

ESCON (Enterprise Systems Connection) connectors were developed by IBM with enhanced features such as a retractable shroud. The duplex connector uses 2.5mm ferrules and is similar in design to the FDDI/FSD connector. High performance versions allow for systems use of both singlemode and multimode fibers. Hybrid ESCON/RSD to MIC/FSD sleeves are available.

The SMA 905 AND 906 are threaded non-keyed connectors only available in multimode. They are not recommended for new designs. Delrin sleeves improve alignment but losses are high (1-2 dB).

The Mini BNC is a bayonet style fiber optic connector used on older IBM systems and compatible products. The predecessor to ST types, this connector is keyed, has a 2.5mm ferrule and uses a bayonet coupling technique.

**Fig. 4-10.** Other Fiber Optic Connectors in use: ST, Biconic, SC, ST Compatible, FC, SMA, FSD, FDDI.

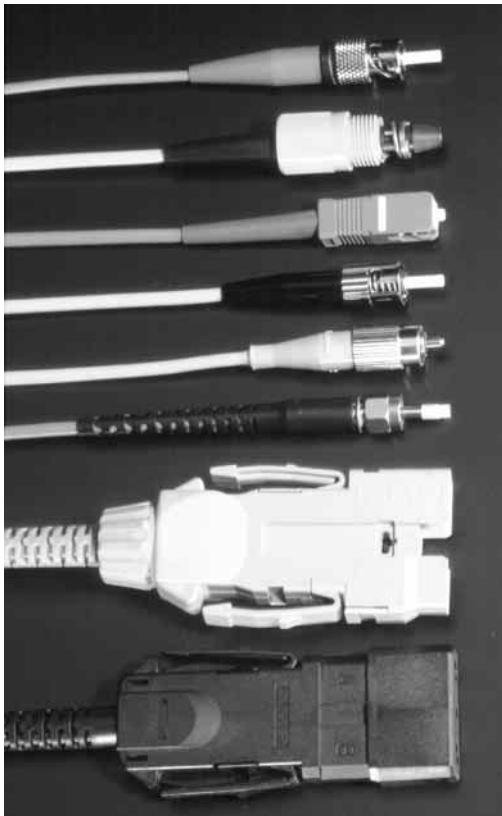

#### 4.7.4 OTHER CONNECTORS - SINGLEMODE

The following connectors are common styles used for singlemode applications. Most can be used for multimode applications but are predominantly used in telecommunications systems.

The FC is a simplex connector with keying features, using the 2.5mm ferrule. The FC continues to be a popular connector style in singlemode systems.

The D-4 is predominantly used in singlemode systems, and offers high performance, but has a disadvantage in lack of users and availability.

The Biconic, introduced in the 1990s, is a non-keyed connector which was generally used in the past by the telephone industry but its use is declining.

Diamond connectors are the highest performance connectors available. Their design utilizes tungsten carbide for high repeatability and low losses. They are primarily used in test equipment and other high-performance products.

**Important:** When using singlemode connectors, reflectivity issues must be addressed; see 4.6.1.

#### 4.7.5 INSTALLING OPTICAL FIBER CONNECTORS INTO WORKSTATION HOUSINGS

Once horizontal fiber cables are run to each work area and connectorized, the last step is to gather the connectorized ends for each work area into a housing. As with many snap-in copper connectivity products these days, the typical optical fiber connector does not directly connect the fiber to the housing. The horizontal optical fiber cables are first terminated to connectors, which are then inserted into the female sleeve of a housing. As always, when installing connectors, handle them carefully (see Section 4.2), following the manufacturer's installation specifications for the housing and connector. For more information on workstation housings, see Section 4.8.



## 4.8 CROSSCONNECT PANELS AND WORKSTATION OUTLETS

### 4.8.1 FIBER OPTIC CLOSET HARDWARE

For fiber optic cable, connecting hardware in the telecommunications closet is primarily enclosed in patch panels. The horizontal cables and the backbone cables are terminated with connectors, and connected to the patch panel couplers on the back of the panels. The cross-connection between the horizontal cables and equipment or backbone cables is done with simplex or duplex patch cords (section 4.8.3).

Distribution panels may also be used. A distribution panel differs from a patch panel in that the interconnections on a distribution panel are intended to be permanent, while patch panels are constructed to provide moveable connections that allow the system to be modified.

In addition, a device called an attenuator may be needed to reduce the optical power levels into the detector, which can be oversaturated with optical power and thus cause an increase in the bit error rate. A fixed attenuator intentionally introduces loss into a system, usually in increments of 5, 10, 15 or 20 dB. It is typically mounted on the Receiver side of the link, in a patch panel.

Figure 4-11. Fiber Optic Patch Panel (rack-mount).



### 4.8.2 FIBER OPTIC PATCH PANELS

Patch panels (Fig. 4-11) are used as Intrabuilding Interconnects or main crossconnects. They provide a central location for patching, testing, monitoring, attenuating and restoring service to fiber optic transmission lines. The patch panel receives the fiber optic patch cords or jumpers from the splice panel or from equipment, and properly routes them to other pieces of equipment.

For Local Area Networks (LANs) the patch panel can accommodate main cross-connects or Intermediate cross-connects to provide a location where personnel can access backbone cabling in intrabuilding links and transmission equipment. Patch panels are available with various connector styles.

Patch panels come in wall or rack mounting styles; the deciding factor on which to use usually comes down to available floor space, and the existence of any other rack-mount equipment. Wall mount panels are usually used where floor space is limited, and there is no rack-mount equipment. Rack-mount panels are generally used where there is sufficient floor space to accommodate racks, and where there will be other rack-mount equipment such as hubs, routers, multiplexers, fiber optics electronics, copper patch panels and wire management products. Both mounting styles can usually be ordered with key-locked doors which provide security by limiting user access.

### 4.8.3 FIBER OPTIC PATCH CORDS

At the crossconnect, circuits are joined with patch cords—lengths of cable with connectors on each end (Fig. 4-12). They may be simplex (one fiber per cable) or, more commonly, duplex (two fibers per cable) form.

Figure 4-12. Fiber Optic Patch Cord.

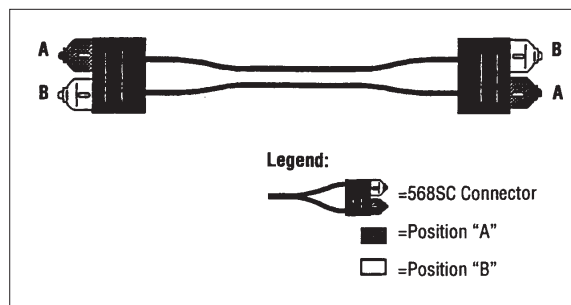

### 4.8.4 OTHER FRAME-SIDE HOUSINGS

**STORAGE CABINETS** are used at the building entrance to store cable loops.

**SPLICE PANELS** (Wall- or rack-mount) are used at building entrances. They allow the user several options on the routing of the fiber optic cable. To meet National Electrical Code (NEC) requirements of providing a transition from outside plant-rated cable to indoor-rated cable (such as riser or plenum-rated cable), the cable must be terminated or spliced within 50 feet of the building entrance.

The splice panel normally has splice trays to handle either fusion or mechanical splices and appropriate cable handling, routing, storage and grounding requirements. All splice trays should be designed to allow proper bend radius for both singlemode and multimode fibers. Other requirements may include the distribution of cables to various equipment rooms, buildings or cross connects in a site. In many cases, controlled access or locks may be required.

**DISTRIBUTION PANELS** (Wall or rack mount) are used at building entrances or hubs and combine both the splicing (permanent connections) and patching (changeable) functions in the same panel. Connector and splice trays may be removable to provide convenient access for maintenance, testing or splicing (Fig. 4-13).

**Fig. 4-13.** Fiber Optic Distribution Panel with Splice Tray Open (rack mount application).

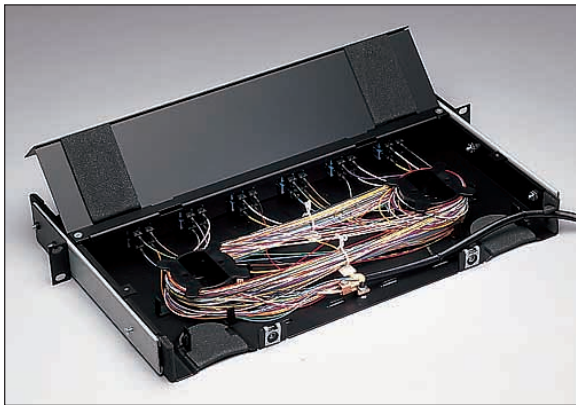

#### 4.8.5 WORKSTATION RECEPTACLES

The proliferation of fiber to the desk has made protection, routing, and availability of optional interfaces very important features to have in workstation outlets. And since most workstations generally use a mix of applications and media types, the flexibility to accommodate multiple media is important for outlet products (see Fig. 4-14).

In selecting a housing for fiber optic connectors, it is recommended that it allow a service loop of at least 1 meter (3 feet)—behind the face plate. Significant space is needed behind the face plate to allow for the backside of the connectors, and to allow minimum bend radius for optical fiber (to prevent excess loss). Since it is very difficult for a technician to properly terminate fiber in a receptacle while kneeling on the floor, the 3' loop allows the technician to bring it up to a work surface for termination.

**Fig. 4-14.** For Maximum Application Versatility, Choose Outlets That Accommodate Multiple Media (fiber and copper cabling).

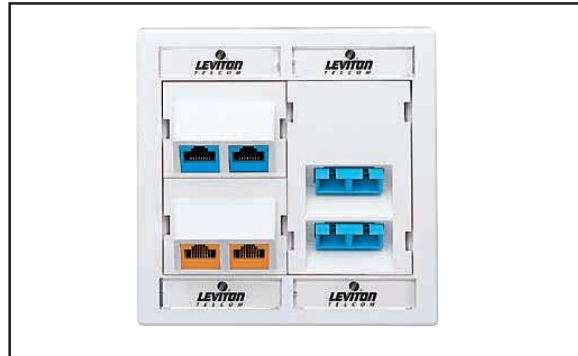

Also note that a standard, shallow 'four square' in-wall box may not be sufficient for housing fiber optic connectors and service loop; check the manufacturer's requirements before installation. A surface mount box may be required to give additional space.

#### 4.8.5.1 Housings—General Issues to Consider

- **Aesthetics.** Appearance is very important to the end-user, especially with fiber-to-the-desk applications. So be sure to choose products which are aesthetically pleasing and do not detract from the work area appearance.
- **Protection of all unused station ports.** It is important to cover unused fiber connectors with dust caps, as dust can settle into unused fiber connectors and degrade performance.
- **Ability to Add, Move and Change.** Make sure that both the patch panel and station outlet you choose are easily adapted to changing needs. For example, an end-user may be using ST connectors in their patch panels, but during an addition wants to use SC connectors. Make sure the bulkhead plates can be changed out to allow you to add or intermix connector types.



## TESTING & TROUBLESHOOTING COMMERCIAL BUILDING FIBER OPTIC CABLE

This section includes: a) Testing procedures for verifying horizontal optical fiber cabling after initial installation, and b) Troubleshooting tips for systems that have been up-and-running. Backbone cabling verification is not covered in this document.

### 4T.1 SYSTEM VERIFICATION TESTING AFTER INITIAL INSTALLATION

Benefits of verification testing. Testing affirms that the loss does not exceed acceptable limits, and ensures that the cable system meets the user's attenuation specifications. It also provides documentation that will be essential to a troubleshooter in gauging whether or not the readings he is getting are normal.

#### 4T.1.1 TEST EQUIPMENT

For basic testing you will need the following equipment: a power meter, an optical source, two test jumpers (of the same connector type and fiber core size), and an interconnection adapter. You will also need one of the following instruments to determine the exact location of any faults you find: an OTDR (optical time domain reflectometer), fault finder, or visual tracer.

#### 4T.1.2 REQUIRED TESTS

Testing the optical properties of fiber optic cable involves measuring two characteristics: attenuation and bandwidth.

*Attenuation* is the measure of signal loss during its travel through the cable, from transmitter to receiver. A small amount of loss is unavoidable, acceptable, and not noticeable by the data. But because the number of spliced/connections can have an effect (more interruptions = more chance for loss), and workmanship/handling is another contributing factor on performance, it is important to test after installation to ensure the cabling system is performing to specification. TIA-568-A compliance requires an end-to-end attenuation test with results within the published specifications.

*Bandwidth* is a measure of the information-carrying capacity of the cable. The quality and length of the fiber determine bandwidth. Installer handling has no effect on this. It is important that a cable system's bandwidth provide the information-carrying capacity required by the end-user. Bandwidth can be verified by simply affirming the documented specifications of the installed

cable type. An actual field test is only necessary if this is not sufficient to determine bandwidth, or if the installer's practice is to run a field test anyway, or if the end-user requires it.

#### 4T.1.3 TESTING PROCEDURE

You will want to read the test equipment manufacturer's instructions for testing, but **here is the general procedure that complies with EIA/TIA-526-14, Method B: Optical Power Loss Measurements of Installed Multimode Fiber Cable Plant.**

Before testing, make sure all connectors, jumpers, and adapters have been properly cleaned.

1. First you need to take a reference reading. Connect a test jumper from the meter to the optical source, set the meter and source to the same wavelength, turn them on, and record the power reading in decibels (dB). This is your REFERENCE READING.

Wavelength settings are generally 850 /1300nm for multimode, and 1310/1550 nm for single mode. In premises environments all the these wavelengths except 1550 nm are commonly used.

(Note: To comply with EIA/TIA-526-14, the light source or OTDR must operate within the range of 850 +/- 30 nm for multimode, and 1300 +/- 20 nm for single mode. Also, the power meter must be calibrated and traceable to the National Institute of Standards Technology.)

2. Next, connect a second jumper (of the same size fiber as the test jumper) to the first test jumper, joining them with an interconnection sleeve. Turn the meter and source on, and record the power level shown on the meter. This second reading is the CHECK READING.

Compare the 'Check Reading' with your initial 'Reference Reading', to make sure that the second jumper did not increase attenuation by more than .75 dB. To do this, subtract your initial Reference Reading from the Check Reading. There should be no more than .75 dB of loss between the first and second reading. (Note that .75 dB is the TIA-568-A threshold, but if desired you may also use the manufacturer-specified Guaranteed Maximum Mated Pair Loss for the specific connector you are using.)

If the reading is satisfactory, proceed to Step 3, the end-to-end attenuation test. If not, clean all connectors except the source connection point, and repeat the Check Reading procedure.

3. Now you are ready to perform the end-to-end attenuation test. Leave both jumpers attached to the optical source and power meter, but disconnect them at the interconnection sleeve. Take the meter and its jumper to one end of the cable being tested, and take the source to the other end. Record the reading; this is your official ATTENUATION TEST READING. Subtract the reference reading (recorded earlier) from the test reading you have just taken, to determine the end-to-end attenuation. Document this reading.

Attenuation should be measured and documented in both directions and at both applicable wavelengths (mentioned in Step 1). Note that a manufacturer may recommend that an OTDR be used to measure attenuation of fibers that will be left unterminated. A visual tracer can be used to confirm continuity.

#### 4T.1.4 BANDWIDTH VERIFICATION

It is not necessary to perform a field test to verify bandwidth if documents or cable labeling allow you to see that the proper bandwidth fiber has been specified. Perform an actual field test only if documentation of the fiber bandwidth is not available.

#### 4T.1.5 OTHER THINGS TO DO BEFORE SYSTEM START-UP

Use the power meter to check the power levels of the transmitter and receiver, after they have been installed and before the system is used. This lets an owner or troubleshooter quickly determine if the electronics are working properly, and provides a valuable maintenance record for subsequent troubleshooting.

Document your findings.

### 4T.2 TIPS FOR TROUBLESHOOTING AN INSTALLED SYSTEM

An optical fiber cabling system that has been correctly installed and tested will require minimal maintenance while providing many years of reliable service. However if a problem does occur in a system, here are some tips to help you troubleshoot it easily.

If all systems have failed, check for a power failure. If power is fine, simply use a methodical approach to isolate the problem (Fig. 4T-1). Start by checking the transmitters and receivers.

First, using a power meter, measure the received power at the receiver. If any light is coming in, then you know that the transmitter and cable are fine so the problem would be the receiver. If however there is no light coming into the receiver, check power at the transmitter.

Only after eliminating the transmitter and receiver as the problem would an OTDR, fault finder or tracer be used to locate a break in the fiber. Note that in LANs, most problems tend to be concentrated in the areas where there is the most access to the fiber—i.e., patch panels. Using Leviton Telcom fiber optic cabinets with locking doors will help prevent such problems in the first place.

Fig. 4T-1. Fiber Optic Troubleshooting Flow Chart

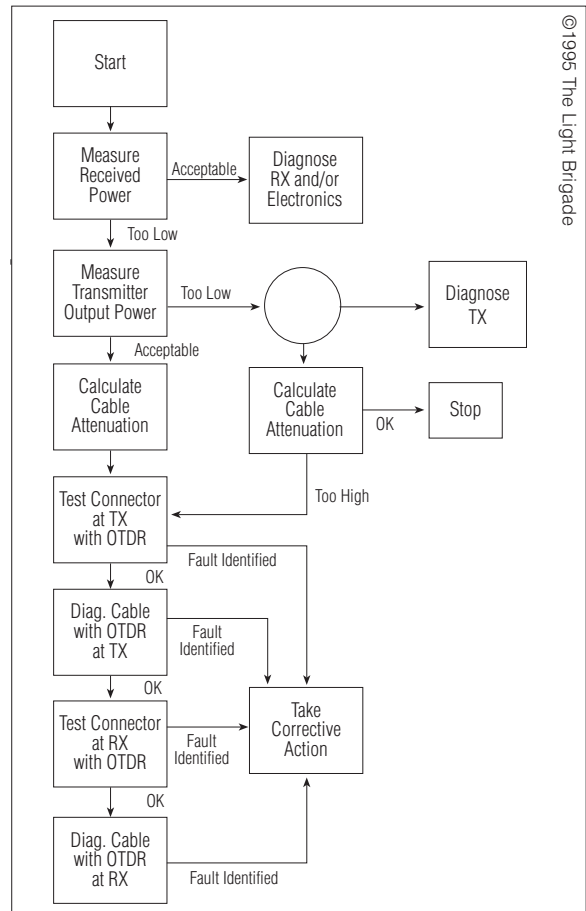

© 1995 The Light Brigade

Fault	Cause	Equipment	Remedy
Bad Connector	Dirt or Damage	Microscope	Cleaning/Polishing
Bad Pigtail	Pigtail Kinked	Visible Laser	Straighten Kink
Localized Cable Attenuation	Kinked Cable	OTDR	Straighten Kink
Distributed Increase In Cable Attenuation	Defective Cable or Installation Specs. Exceeded	OTDR Replace	Reduce Stress/Replace
Lossy Splice	Increase in Splice Loss Due to Fiber Stress in Closure	OTDR/Visible Laser	Open & Redress
Fiber Break	Cable Damage	OTDR/Fault Finder	Repair/Replace



## APPENDIX A GLOSSARY

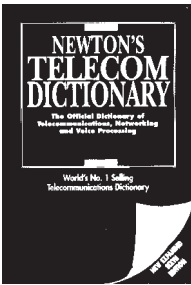

Most of these definitions have been extracted (with editing for space restrictions) from **Newton's Telecom Dictionary (6th Edition)**, published by **Telecom Library, Inc.** To purchase a copy, write to: **Telecom Library, 12 West 21 Street, New York, NY 10010. Telephone: (212) 691-8215 or 1-800-LIBRARY.**

### A

**ATM** Asynchronous Transfer Mode. ATM is a high bandwidth, low delay, packet-like switching and multiplexing technique. Usable capacity is segmented into fixed-size cells, consisting of header and information fields.

**Attenuation** The decrease in the power of a signal, light beam, or light wave. Measured in decibels. Opposite of gain.

**AWG** American Wire Gauge. Standard measuring gauge for non-ferrous conductors (i.e., non-iron and non-steel). Gauge is a measure of the diameter of the conductor (the thickness of the cable).

### B

**Backbone Wiring** The physical/electrical interconnections between telecommunications closets and equipment rooms. Cross-connect hardware and cabling in the Main and Intermediate Cross-Connects are considered part of the backbone wiring.

**Bandwidth** The difference between the highest and the lowest frequencies of a transmission channel (path for information transmission). Identifies the amount of data that can be sent through a given channel. Measured in Hertz (Hz); higher bandwidth numbers mean higher data capacity.

**BICSI** (Building Industry Consulting Service International) Bicsi is a non-profit industry association, concerned with promoting correct methods for all aspects of the installation of communications wiring.

**Bus** A network topology in which nodes are connected to a single cable with terminations at each end.

### C

**Channel** The end-to-end transmission path between two points at which application-specific equipment is connected.

**CO** Central Office. Telephone company facility where subscribers' lines are joined to switching equipment for connection to each other, locally and long distance. Sometimes the same as the overseas term "public exchange".

**Coaxial Cable** A cable composed of an insulated central conducting wire wrapped in another cylindrical conductor (the shield). The whole thing is usually wrapped in another insulating layer and an outer protective layer. A coaxial cable has great capacity to carry vast quantities of information. It is typically used in high-speed data and CATV applications.

**Compliance** A wiring device that meets all characteristics of a standard is said to be in compliance with that standard. Example: a data jack meeting all of the physical, electrical & transmission standards for TIA-568A Category 5 is compliant with that standard. See also *Device* and *Performance*.

**Conductor** Any substance, usually a wire or cable, that can carry (i.e., offer a relatively small opposition to the passage of) an electrical current.

**Connecting Block** Also called a terminal block, a punch-down block, a quick-connect block, a crossconnect block. A plastic block containing metal wiring terminals to establish connections from one group of wires to another. Usually each wire can be connected to several other wires in a bus or common arrangement. There are several types of connecting blocks: 66 clip, BIX, Krone, 110, etc. A connecting block has insulation displacement connections (IDCs), which means you don't have to remove insulation from around the wire conductor before you "punch it down" (terminate it).

**Connector** A device that connects wires or fibers in cable to equipment or other wires or fibers. Wire and optical connectors most often join transmission media to equipment or cross connects. A connector at the end of a telephone cable or wire is used to join that cable to another cable with a mating connector or to some other telecommunications device.

**Crossconnect** Distribution system equipment used to terminate and administer communication circuits. In a wire crossconnect, jumper wires or patch cords are used to make circuit connections. In an optical crossconnect, fiber patch cords are used. The crossconnect is located in an equipment room, riser closet, or satellite closet.

**Crosstalk** See *Near-End Crosstalk*.

### D

**Daisy Chain** In telecommunications, a wiring method where each telephone jack in a building is wired in series from the previous jack. Daisy chain is NOT the preferred wiring method, since a break in the wiring would disable all jacks "downstream" from the break. See also *Home Run*.

**dB (Decibel).** A dB is a unit of measure of signal strength, usually the relation between a transmitted signal and a standard signal source. Every 3 dB = 50% of signal strength, so therefore a 6 dB loss = a loss of 75% of total signal strength.

**Demarcation Point** The point of interconnection between telephone company facilities and your building wiring. The demarcation point ("demarc") shall be located on the subscriber's side of the telephone company's protector, or the equivalent thereof in cases where a protector is not required.

**Device** As distinguished from equipment. In telecommunications, a "device" is the physical interconnection outlet. Equipment (a computer, phone, fax machine, etc.) then plugs into the device. See also *Equipment* and *Plug*.

**Distribution Device** A facility located within the dwelling unit for interconnection or cross connection.

**Drop Wire** Outside wire pair(s) from the telco plant (cable), to a house or building for connection to a protector.

**DTMF** Acronym for Dual Tone, Multi-Frequency. See *Tone Dial*.

## E

**Electromagnetic Interference (EMI)** The interference in signal transmission or reception caused by the radiation of electrical and magnetic fields.

**Equipment** As distinguished from Device. Telecommunications equipment (computers, phones, faxes, etc.) plug into the telecommunications outlet or device. See also *Device*.

**Ethernet** A local area network used for connecting computers, printers, workstations, terminals, etc. within the same building. Ethernet operates over twisted pair wire and over coaxial cable at speeds up to 10 Mbps. Ethernet LANs are being promoted by DEC, Intel and Xerox. Compare with *Token Ring*.

## F

**FDDI** Fiber Distributed Data Interface. FDDI is a 100 Mbps fiber optic LAN. It is an ANSI standard. It uses a "counter-rotated" Token ring topology. An FDDI LAN is typically known as a "backbone" LAN. It is used for joining file servers together and for joining other LANs together.

## G

**Gain** The increase in signaling power that occurs as the signal is boosted by an electronic device. Measured in decibels (dB).

## H

**Headroom (also called Overhead or Margin)** The number of decibels by which a system exceeds the minimum defined requirements. The benefit of headroom is that it reduces the bit-error rate (BER), and provides a performance 'safety net' to help ensure that current and future high speed applications will run at peak accuracy, efficiency and throughput.

**Home Run** Phone system wiring where the individual cables run from each phone directly back to the central switching equipment. Home run cabling can be thought of as "star" cabling. Every cable radiates out from the central equipment. All PBXs and virtually all key systems work on home run cabling. Some local area networks work on home run wiring. See also *Star Wiring*, *Daisy Chain*.

**Hub** The point on a network where a bunch of circuits are connected. Also, a switching node. In Local Area Networks, a hub is the core of a star as in ARCNET, StarLAN, Ethernet, and Token Ring. Hub hardware can be either active or passive. Wiring hubs are useful for their centralized management capabilities and for their ability to isolate nodes from disruption.

**Hybrid Connector** A connector containing both optical fiber and electrical conductors.

## I

**Insulation Displacement Connection (IDC)** A type of wire

termination in which the wire is "punched down" into a metal holder which cuts into the insulation wire and makes contact with the conductor, thus causing the electrical connection to be made.

**IDF** Intermediate Distribution Frame. A metal rack designed to connect cables and located in an equipment room or closet. Consists of components that provide the connection between inter-building cabling and the intra-building cabling, i.e. between the Main Distribution Frame (MDF) and individual phone wiring. There's usually a permanent, large cable running between the MDF and IDF. The changes in wiring are done at the IDF. This saves confusion in wiring.

**IEEE 802.3** IEEE stands for the Institute of Electrical and Electronic Engineers, a publishing and standards-making body responsible for many standards used in LANs, including the 802 series. Ethernet and StarLAN both follow the 802.3 standard. Typically they transmit at 10 megabits per second. This is the most common local area network specification.

**Impedance** The total opposition (i.e. resistance and reactance) a circuit offers to the flow of alternating current. It is measured in ohms, and the lower the ohmic value, the better the quality of the conductor.

**Interconnect** 1. A circuit administration point, other than a crossconnect or an information outlet, that provides capability for routing and rerouting circuits. It does not use patch cords or jumper wires, and typically is a jack-and-plug device used in smaller distribution arrangements or that connects circuits in large cables to those in smaller cables. 2. An *Interconnect Company* is one which sells, installs, and maintains telephone systems for end users, typically businesses.

**ISDN** Integrated Services Digital Network. According to AT&T, today's public switched phone network has many limitations; ISDN's vision is to overcome these deficiencies.

## J

**Jack** A receptacle used in conjunction with a plug to make electrical contact between communication circuits. Jacks and their associated plugs are used in a variety for connecting hardware applications including cross connects, interconnects, information outlets, and equipment connections. Jacks are used to connect cords or lines to telephone systems. A jack is the female component of a plug/jack connector system, and may be standard, modified, or keyed. See also *Plug* and *RJ*.

## L

**LAN** Local Area Network. A short distance network (typically within a building or campus) used to link together computers and peripheral devices (such as printers) under some form of standard control.

**Link** A transmission path between two points, not including terminal equipment, work area cables and equipment cables.

**Loop** 1. Typically a complete electrical circuit. 2. The loop is also the pair of wires that winds its way from the central office to the telephone set or system at the customer's office, home or factory (i.e., 'premises' in telephony terms).

**M**

**Mbps** MegaBits Per Second. One million bits per second.

**MDF** Main Distribution Frame. A wiring arrangement which connects the telephone lines coming from outside on one side and the internal lines on the other. A main distribution frame may also carry protective devices as well as function as a central testing point.

**MHz** MegaHertz. A unit of frequency denoting one million Hertz (i.e., 1,000,000 cycles per second).

**MMJ** Modified Modular Jack. A six-wire modular jack with the locking tab shifted off to the right hand side. Used in the DEC wiring system.

**Modular** Equipment is said to be modular when it is made of "plug-in units" which can be added together to make the system larger, improve the capabilities, or expand its size.

**Multimedia** Applications that communicate information by more than one means.

**N**

**Near-End Crosstalk (NEXT)** Electrical noise coupled from one pair of wires to another within a multi-pair cable.

**Network** A network ties things together. Computer networks connect all types of computers and computer-related things—terminals, printers, modems, door entry sensors, temperature monitors, etc. The networks we're most familiar with are long distance ones, like phones and trains. Local Area Networks (LANs) connect computer equipment within a building or campus.

**O**

**Off-Hook** When the handset is lifted from its cradle, it's off-hook. The term originated when the early handsets were actually suspended from a metal hook on the phone. In modern phones, when the handset is removed from its hook or cradle, it completes the electrical loop, thus signaling the central office to provide dial tone.

**On-Hook** When the phone handset is resting in its cradle. The phone is not connected to any particular line. Only the bell is active—i.e., it will ring if a call comes in. Opposite of *Off-Hook*.

**Open (Fault)** Means that the circuit is not complete or the cable/fiber is broken.

**Outlet** A telecommunications outlet is a single-piece cable termination assembly (typically on the floor or in the wall), containing one or more modular telecom jacks. Such jacks might be RJs, coaxial terminators, fiber optic couplers, etc. See also *Device* and *Equipment*.

**P**

**Part 68 Requirements** Specifications established by the FCC as the minimum acceptable protection communications equipment must provide the telephone network.

**Patching** A means of connecting circuits via cords and connectors that can be easily disconnected and reconnected at another point. May be accomplished by using modular cords

connected between jack fields or by patch cord assemblies that plug onto connecting blocks.

**PBX** Private Branch Exchange. A small, privately-owned version of the phone company's larger telephone central switching office.

**Performance** Compare with Compliance. A device can exhibit performance characteristics without being compliant to an industry standard.

**Plug** A male component of a plug/jack connector system. In premises wiring, a plug provides the means for a user to connect communications equipment to the communications outlet.

**Polarity** Which side of an electrical circuit is the positive? Which is the negative? Polarity is the term describing which is which.

**POTS** Plain Old Telephone Service. The basic service supplying standard single line telephones, telephone lines and access to the public switched network. Just receive and place calls. No added features like Call Waiting or Call Forwarding.

**Power Sum** A test method for four pair cable whereby the mathematical sum of pair-to-pair crosstalk from three pairs to one pair is measured.

**Premises** Telephony term for the space occupied by a customer or authorized/joint user in a building(s) on continuous or contiguous property (except railroad rights of way, etc.) not separated by a public road or highway.

**Premises Wiring System** The entire wiring system on the user's premises, especially the supporting wiring that connects the communications outlets to the network interface jack.

**R**

**RBOC** Regional Bell Operating Company. Seven RBOCs exist, each of which owns two or more Bell Operating Companies (BOCs). The RBOCs were carved out of the old AT&T/Bell System during the divestiture of the Bell operating companies from AT&T in 1984.

**RCDD** The RCDD (Registered Communications Distribution Designer) title is a professional rating granted by BICSI (the Building Industry Consulting Service International). RCDDs have demonstrated a superior level of knowledge of the telecommunications wiring industry and associated disciplines.

**Return Loss** A measure of the similarity of the impedance of a transmission line and the impedance at its terminations. It is a ratio, expressed in decibels, of the power of the outgoing signal to the power of the signal reflected back.

**Ring** As in Tip and Ring. One of the two wires needed to set up a telephone connection. See *Tip*.

**RJ** Registered Jack. RJs are telephone and data jacks/applications registered with the FCC. Numbers, like RJ-11, RJ-45, etc. are widely misused in the telecommunications industry. A much more precise way to identify a jack is to specify the number of positions (width of opening) and number of conductors. Example: "8-position, 8-conductor jack" or "6-position, 4-conductor jack".

A  
P  
P  
E  
N  
D  
I  
XA  
GLOSSARY

## S

**Series Wiring** See *Daisy Chain*.

**Service Loop** When a device is terminated to the wire in the communications outlet, a fair amount of "slack" should be left on the wire and wound in the box to accommodate future trimming when devices are changed out.

**Splice** The joining of two or more cables together by connecting the conductors pair-to-pair.

**Standards** Agreed principles of protocol. Standards are set by committees working under various trade and international organizations.

**Star Wiring** See *Home Run*.

## T

**T1** A standard for digital transmission in North America. A digital transmission link with a capacity of 1.544 Mbps (1,544,000 bits per second.) T1 lines are used for connecting networks across remote distances. Bridges and routers are used to connect LANs over T1 networks.

**Talk Battery** The DC voltage supplied by the central office to the subscriber's loop so as to allow you to have a voice conversation.

**Telco** An Americanism for TELEphone COmpany.

**Ten Base-T** See *10Base-T* at end of Glossary.

**Terminate** To connect a wire conductor to something, typically a piece of equipment.

**Tip** 1. The first wire in a pair of wires. (The second wire is called the "ring" wire.) 2. A conductor in a telephone cable pair which is usually connected to positive side of a battery at the telco. It is the phone industry's equivalent of Ground in a normal electrical circuit. See *Ring*.

**Tone Dial** A push-button telephone dial that makes a different sound (in fact, a combination of two tones) for each number pushed. The technically correct name for tone dial is Dual Tone Multi Frequency, or DTMF.

**Token Ring** A ring topology for a local area network (LAN) in which a supervisory frame, or token, must be received by an attached terminal or workstation before that terminal or workstation can start transmitting. The workstation with the token then transmits and uses the entire bandwidth of whatever communications media the token ring network is using.

A token ring can be wired as a circle or a star, with the workstations wired to a central wiring center, or to multiple wiring centers. The most common wiring scheme is called a star-wired ring. Whatever the wiring, a token ring LAN always works logically as a circle, with the token passing around the circle from one workstation to another.

The advantage of token ring LANs is that media faults (broken cable) can be fixed easily, since it's easy to isolate the faults. Token rings are typically installed in centralized closets, with loops snaking to served workstations.

**Topology** As in network topology. The geometric physical or electrical configuration describing a local communication network; the shape or arrangement of a system. The most common topologies are the bus, ring and star.

**TP-PMD** Twisted Pair - Physical Media Dependent. Technology under review by the ANSI X3T9.5 working group that allows 100 Mbps transmission over twisted-pair cable.

**Twisted Pair** Two insulated copper wires twisted around each other to reduce induction (thus interference) from one wire to the other. The twists, or lays, are varied in length to reduce the potential for signal interference between pairs. Several sets of twisted pair wires may be enclosed in a single cable. In cables greater than 25 pairs, the twisted pairs are grouped and bound together.

## U

**UL** Underwriters Laboratories, a privately owned company that tests to make sure that products meet safety standards. UL also administers a program for the certification of Category-Rated Cable.

**USOC** Universal Service Order Code. An old Bell system term identifying a particular service or equipment offered under tariff.

**UTP** Unshielded Twisted Pair. See *Twisted Pair*.

## W

**Workstation** The working area in a building required by one telecommunications user. Industry standards call for one voice drop and one data drop for each workstation. The voice drop is one 4-pair unshielded twisted pair (UTP). The data drop may be 100Ω 4-pair UTP, 150Ω 2-pair shielded twisted pair (STP), or optical fiber.

## 10BASE-T

An IEEE standard for operating Ethernet local area networks (LANs) on twisted-pair cabling using the homerun method of wiring (exactly the same as a phone system does), and a wiring hub which will contain electronics performing similar functions to a telephone switch.

The full name for the standard is IEEE 802.3 10Base-T. It defines the requirement for sending information at 10 million bits per second on ordinary unshielded twisted-pair cabling and defines various aspects of running Ethernet on this cabling, such as:

- Connector types (typically eight-pin RJ-45)
- Pin connections (1 and 2 for transmit, 3 and 6 for receive.)

**100BASE-T** Provides one gigabit per second ethernet over 4 pair Category 5 cabling up to 100 meters.

**1000BASE-T** Provides 100 mbps per second ethernet over 2 pairs of Category 5 cabling up to 100 meters.



## APPENDIX B NETWORK DIAGRAMS

### CATEGORY 5 APPLICATION SUMMARY

Though not an actual application, Category 5 is a structured wiring system standard which many other applications and emerging standards require for proper operation.

The Telecommunications Industry Association (TIA) established standards for building cabling with the publication of the TIA/EIA 568 Commercial Building Wiring Standard. Subsequently, the TIA issued TSB-36 and TSB-40 (Technical Service Bulletins) which defined the category rating system as it applies to UTP cabling and connectors. Category 5 extended the characterization of the wiring system to 100 MHz. The TIA has developed a revision of TIA/EIA-568 which incorporated the TSBs into the main body of the standard, now called TIA/EIA-568A. Leviton QuickPort® and InfoTap® Category 5 products fully meet the requirements of TIA/EIA-568A for category compliance.

Note: For a fully TIA/EIA-568A Category 5 compliant network system, all components must be rated Category 5 and be correctly installed to either the T568A or T568B wiring scheme with all pairs terminated.

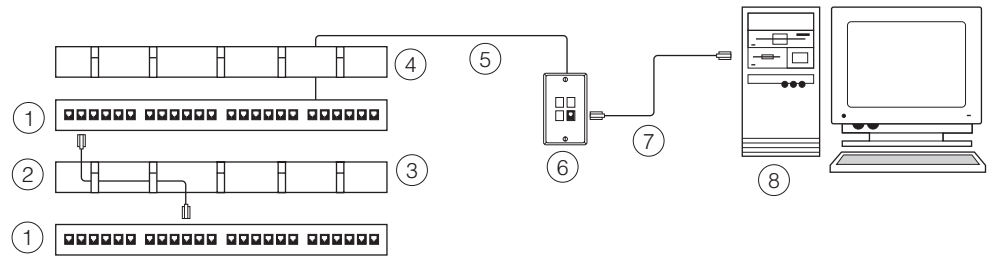

#### CABLING COMPONENTS

- |            |                                    |         |  |
|------------|------------------------------------|---------|--|
| Part ..... | Description                        | 6 ..... | QuickPort® Category 5 Jack ✓             |
| 1 .....    | Category 5 Patch Panel ✓           | .....   | QuickPort® Information Outlet Housing ✓  |
| 2 .....    | Category 5 Patch Cords ✓           | 7 ..... | Category 5 Station/Patch Cord ✓          |
| 3,4 .....  | Front/Rear-Side Cable Management ✓ | 8 ..... | PC equipped with required interface card |
| 5 .....    | Category 5 4-Pair UTP              |         |  |

✓ Note: Call for Leviton Telcom part numbers.

### 10BASE-T (ETHERNET) APPLICATION SUMMARY

IEEE 802.3 defines the standard for 10Base-T (Ethernet) communications over unshielded twisted pair (UTP) for local area networks as both a physical link and a data link protocol. A minimum Category 3 cabling system must be installed to insure the proper operation of 10Base-T networks: most users now choose to upgrade their cabling infrastructure to higher levels of performance. The physical connection described in IEEE 802.3 for network connection is an 8-position modular jack (see diagram page C-1). **Note that any system fully wired to either T568A or T568B wiring schemes will support 10Base-T applications.**

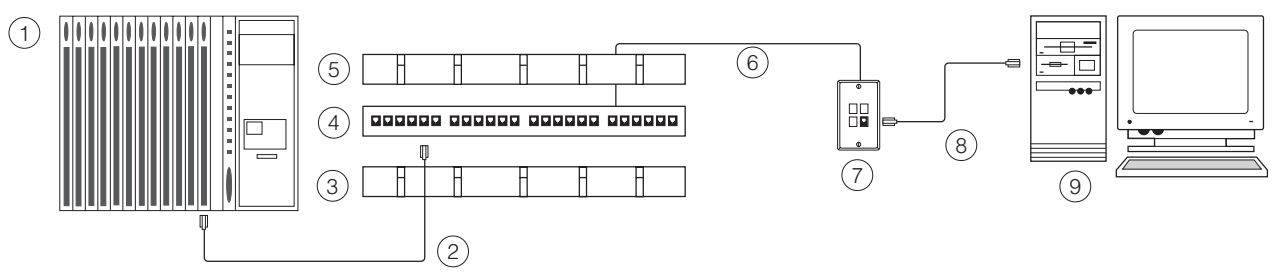

#### CABLING COMPONENTS

- |            |                                    |                                    |  |
|------------|------------------------------------|------------------------------------|--|
| Part ..... | Description                        | 7 .....                            | QuickPort® Category 3 or 5 Jack ✓        |
| 1 .....    | 10BASE-T Hub                       | .....                              | QuickPort® Information Outlet Housing ✓  |
| 2 .....    | Patch Cords ✓                      | (4-Port QuickPort Wallplate Shown) |  |
| 3,5 .....  | Front/Rear-Side Cable Management ✓ | 8 .....                            | Station/Patch Cord ✓                     |
| 4 .....    | Patch Panel, Category 3, 4 or 5 ✓  | 9 .....                            | PC equipped with required interface card |
| 6 .....    | 4-Pair UTP                         |                                    |  |

✓ Note: Call for Leviton Telcom part numbers.



## TOKEN RING APPLICATION SUMMARY

IEEE 802.5 defines the Token Ring topology as a baseband network where a supervisory frame or token passes from PC to PC, allowing each PC in turn to transmit over the entire bandwidth of the network. The most common cabling scheme is a "star-wired ring" where each PC is connected in a star fashion to a centrally located MAU (Multistation Access Unit) which automatically "heals" the ring if one PC is turned off or its cable is broken. Operating at either 4 or 16 Mbps, it is common to use Category 3 UTP at a minimum (for 4 Mbps Token Ring); UTP rated at least Category 4 is required for 16 Mbps Token Ring, with most owners opting to upgrade to Category 5.

### WIRING DIAGRAM

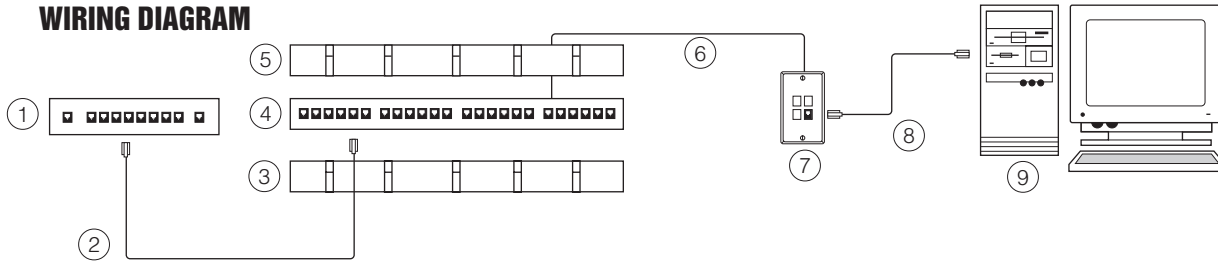

### CABLING COMPONENTS

Part .....	Description	7 .....	Description
1 .....	Token Ring MAU	7 .....	QuickPort® Category 3 or 5 Jack ✓
2 .....	Patch Cords ✓		QuickPort Information Outlet Housing ✓
3,5 .....	Front/Rear-Side Cable Management ✓	8 .....	Station/Patch Cord ✓
4 .....	Patch Panel, Category 3, or 5 ✓	9 .....	PC equipped with required interface card
6 .....	4-Pair UTP		

✓ Note: Call for Leviton Telcom part numbers.

## ATM (ASYNCHRONOUS TRANSFER MODE) APPLICATION SUMMARY

ATM is a high-bandwidth, "high-speed" packet-like switching and multiplexing technique, initially proposed for data rates up to 155 Mbps and higher. Data encoding methods allow higher data bit rates at lower frequencies (e.g. 155 Mbps can run over 100Mhz rated cable.) The proposed cabling media are Category 3, Category 5 and multimode fiber. Category 5 cabling systems are recommended as they will meet all UTP-based proposals emerging from the ATM Forum. (The ATM proposals are being developed by a forum of over 120 application/hardware suppliers.)

### WIRING DIAGRAM

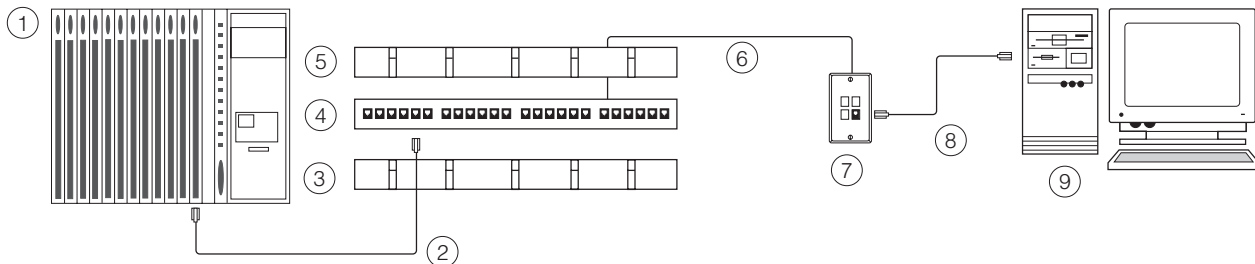

### CABLING COMPONENTS

Part .....	Description	7 .....	Description
1 .....	ATM Hub	7 .....	QuickPort® Category 5 Jack ✓
2 .....	Category 5 Patch Cords ✓		QuickPort Information Outlet Housing ✓
3,5 .....	Front/Rear-Side Cable Management ✓	8 .....	Category 5 Station/Patch Cord ✓
4 .....	Patch Panel, Category 5 ✓	9 .....	PC equipped with required interface card
6 .....	Category 5 4-Pair UTP		

✓ Note: Call for Leviton Telcom part numbers.

# APPENDIX C JACK PIN DESIGNATIONS & COLOR CODES

## Standard 4-Pair Wiring Color Codes

PAIR 1	T	White/Blue
	R	Blue/White
PAIR 2	T	White/Orange
	R	Orange/White
PAIR 3	T	White/Green
	R	Green/White
PAIR 4	T	White/Brown
	R	Brown/White

Note: For 6-wire jacks use pair 1, 2 and 3 color codes.  
For 4-wire jacks use pair 1 and 2 color codes.

Pin #	Jack Type		
	8P8C/8P8C Keyed	6P6C	MMJ
1	Blue (L)	White (W)	Orange (O)
2	Orange (O)	Black (B)	Green (G)
3	Black (B)	Red (R)	Red (R)
4	Red (R)	Green (G)	Yellow (Y)
5	Green (G)	Yellow (Y)	Black (B)
6	Yellow (Y)	Blue (L)	Brown (N)
7	Brown (N)	—	—
8	White (W)	—	—

## 6P4C

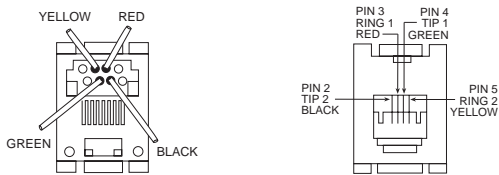

## 6P6C

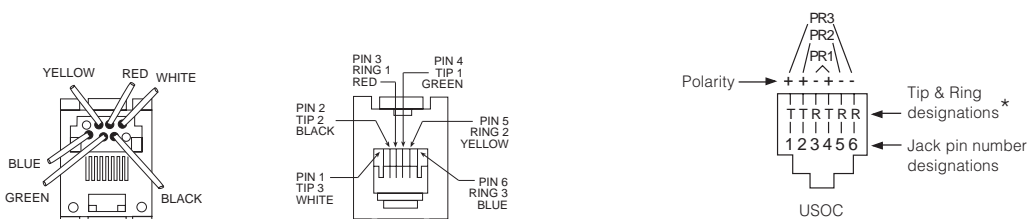

\*Some equipment standards may vary from the standards shown here.

## MMJ

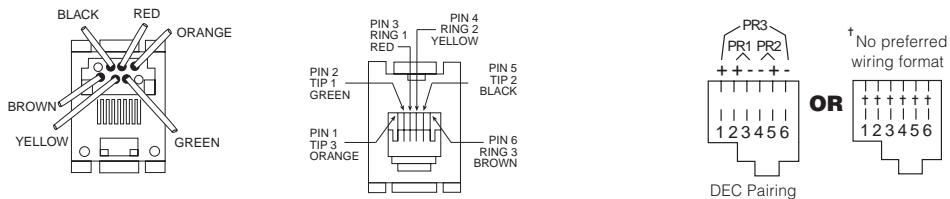

## 8P8C and 8P8C KEYED, USOC

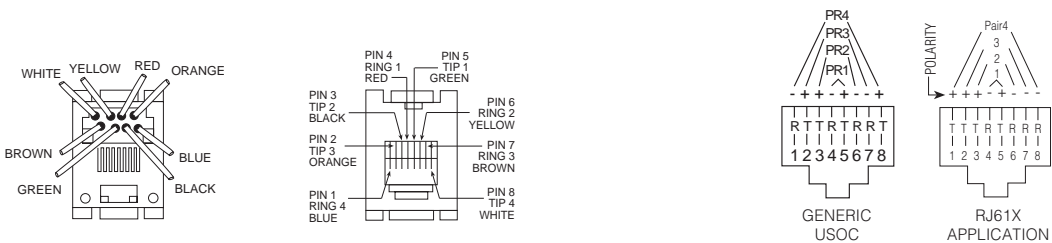

## 8P8C and 8P8C KEYED, T568A, T568B (WECO), 10Base-T

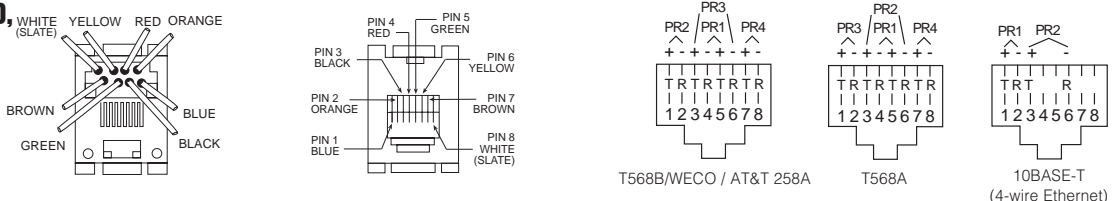

## 25-PAIR COLOR CODING/ISDN CONTACT ASSIGNMENTS

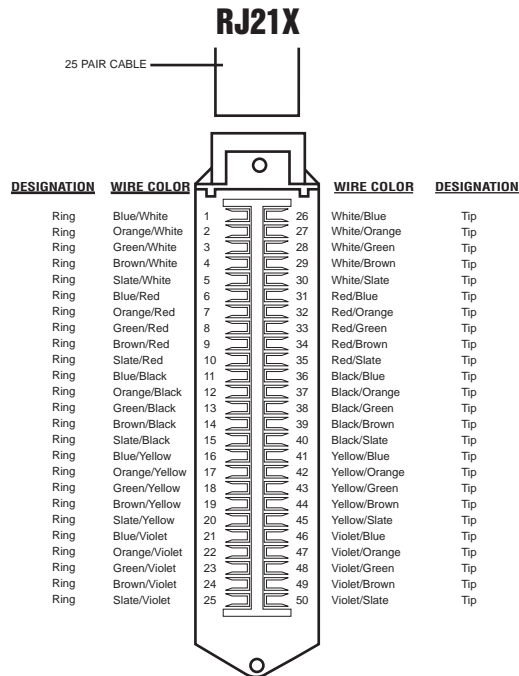

### Electrical Network Connection

From one to twenty-five single or multiple-pair circuits bridged to the network or other connected equipment.

### Mechanical Arrangement

Circuits are provided on numbered tip and ring positions on a miniature 50-pin ribbon connector ("Amphenol-type"). Pins 1 (ring) and 26 (tip) are considered position 1. Pins 2 (ring) and 27 (tip) of the ribbon connector are position 2. This pairing continues through twenty-five pairs.

### Typical Usage

Many key and PBX systems specify the RJ21X as the network interface device. Many of these systems also use the RJ21X, or "Amphenol-type" as a connector for stations or telephone sets, wired from the KSU or PBX Main Distribution Frame.

Note: Sometimes an RJ11 or RJ14C jack can be installed in place of an RJ21X jack. If the system requires only a few lines but the RJ21X is specified on the registration label, under FCC Part 68 you may specify an RJ11C, RJ14C, RJ25C or RJ61X instead.

Many Leviton jacks can be used for the RJ21X configuration where "intermixing" is permitted. Substitution of these special jacks is often both economical and practical. Contact Leviton Telcom Applications Engineering for information about versions to meet your requirements.

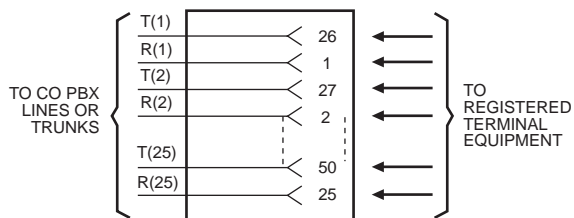
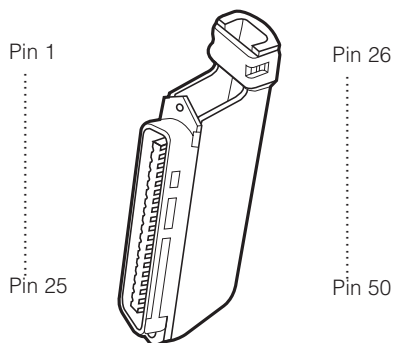

### ISDN Assignment of Contact Numbers as specified by ISO Document 8877: 1987 (E)

Contact assignments for plugs and jacks:

Contact Number	TE	NT	Polarity
1	Power source 3	Power sink 3	+
2	Power source 3	Power sink 3	-
3	Transmit	Receive	+
4	Receive	Transmit	+
5	Receive	Transmit	-
6	Transmit	Receive	-
7	Power sink 2	Power source 2	-
8	Power sink 2	Power source 2	+

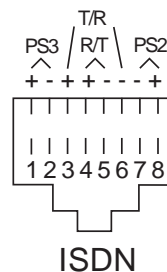

Note: For use in TE to TE interconnections, power source/sink 3 shall conform to the requirements specified in CCITT Recommendation 1.430, section 9.2 for power source/sink 2.

## 66 BLOCK WIRING & CABLE COLOR CODING

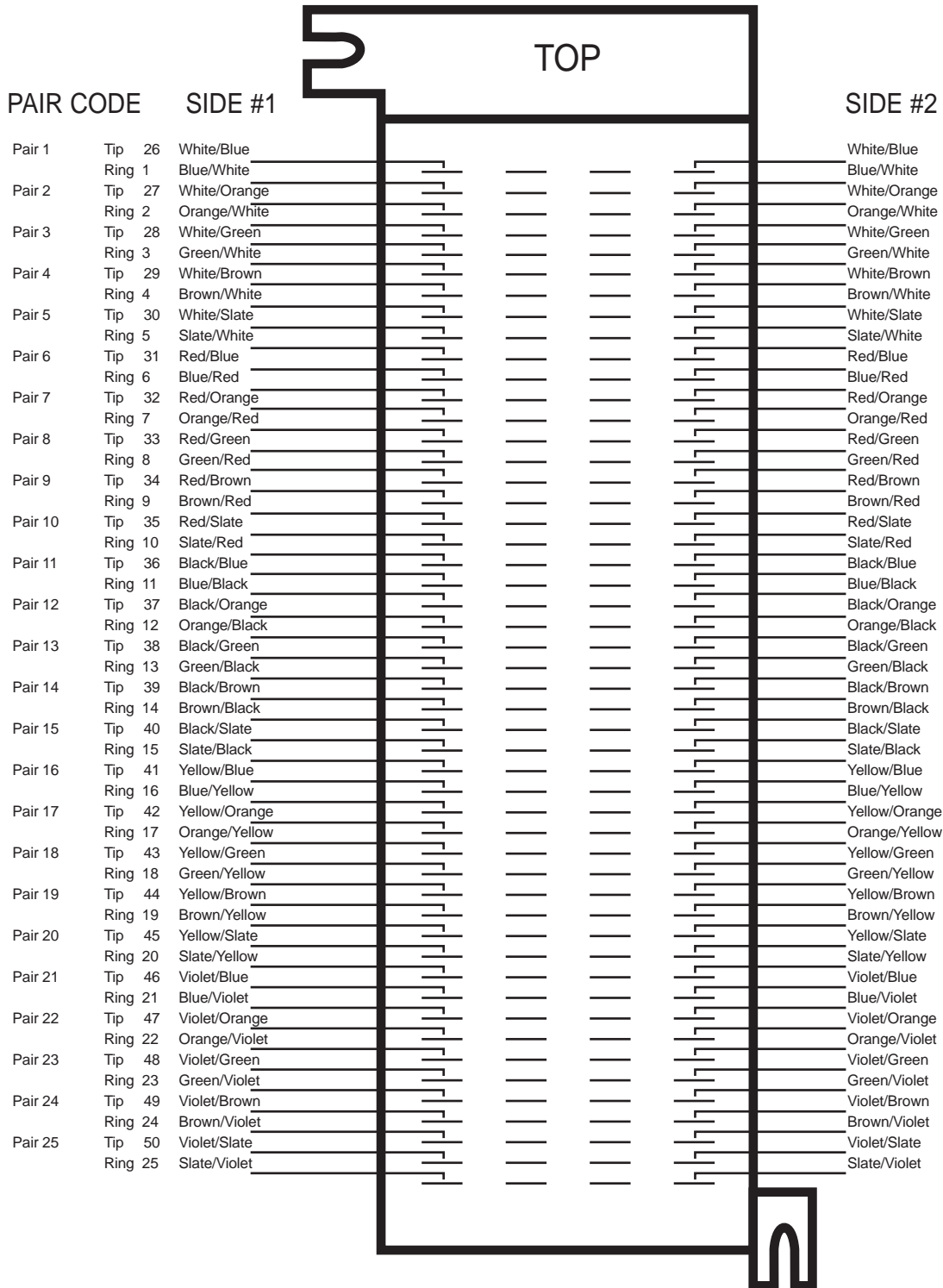

## APPENDIX D USOC CODES

This appendix contains descriptions of Universal Service Order Codes (USOC) for connecting telephone instruments and related equipment to telephone lines, based on Part 68, Subpart F, Section 68.502 of FCC regulations, and as described by the T1E1.3 Working Group on Connectors and Wiring Arrangements.

### A NOTE ABOUT USOC CODES

USOC Codes, developed years ago by the Bell operating companies to identify service or equipment under tariff. Information on USOC codes is provided here should you run across these in your work.

#### APPLICATION CROSS REFERENCE

Application:	USOC Number:
Single-line telephone instruments .....	RJ11
Single-line accessories .....	RJ11
Connecting modems to telephone lines .....	RJ11
Answering machines .....	RJ11
Two-line telephone instruments or accessories .....	RJ14
Connecting three lines to a single telephone set .....	RJ25C
Multiple-line answer/announce systems .....	RJ25C
Burglar and fire alarm circuits .....	RJ31X, RJ38X
Fixed loss loop .....	RJ45
Programmed data equipment .....	RJ45
Up to four access lines .....	RJ61X
1.544 Mbps digital services or other data services ...	RJ48

NOTE: RJ21X can be found on page C-2.

### A Note About USOC Number Suffixes

RJ (Registered Jack) numbers end with a letter that indicates the wiring or mounting method:

“C” identifies a surface or flush-mounted jack.

“W” identifies a wall-mounted jack.

“X” identifies a complex multi-line or series type jack.

### RJ11C/RJ11W

**Important:** Refer to "note on USOC codes" page 2-8.

**Electrical Network Connection:** Single-line connection with bridged tip and ring

**Mechanical Arrangement:** Miniature surface-mount six-position jack (RJ11C), or miniature wall-mount six-position jack (RJ11W)

**Typical Usage:** Connects single line to a telephone instrument or other device (such as a modem or answering machine) in a residence or small business. RJ11 connectors are often specified for small key and PBX systems, wiring one line to one device to simplify installation, troubleshooting, and repair. Connects single-line telephones to individual extensions of a PBX that requires only tip and ring.

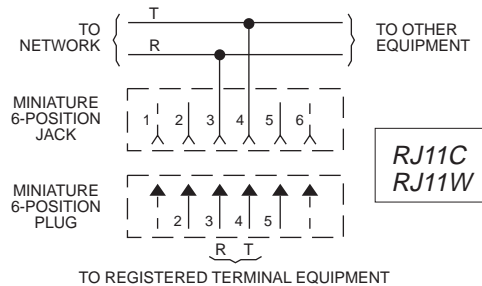

**Note:** In both RJ11C and RJ11W connectors, only two terminals are wired. Green (tip) connects to position 4 and Red (ring) to position 3 of the connector. The connection is bridged (parallel) like a duplex on a branch circuit. There are no other connections to any other pins on the connector.

### RJ14C/RJ14W

**Electrical Network Connection:** Two-line bridged tip and ring.

**Mechanical Arrangement:** Miniature surface-mount six-position jack (RJ14C) or miniature wall-mount six-position jack (RJ14W)

**Typical Usage:** Connects two lines to a single telephone set or other device. Often used in small key system and two-line residence applications. Note: Two lines are bridged (connected in parallel) on positions 3 and 4 (line 1) and on positions 2 and 5 (line 2).

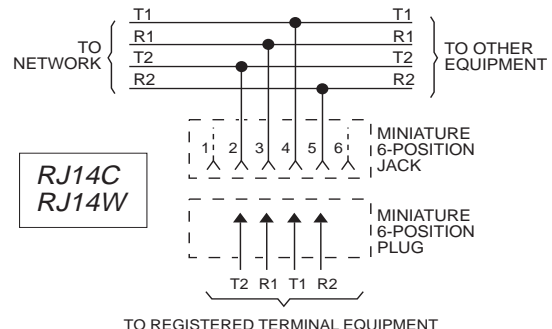



## RJ25C

### Electrical Network Connection:

Three tip and ring circuits (lines). Connection to a single six-position device in bridged configurations.

**Mechanical Arrangement:** Miniature flush-mount six-position bridged three-line jack.

### Typical Usage:

Connects three lines to a single telephone set or other device. Three lines are bridged (connected in parallel). This configuration is normally used for special applications such as message registration, multiple-line answer/announce systems, and similar services.

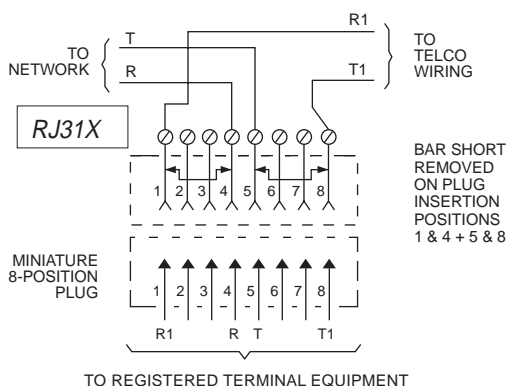
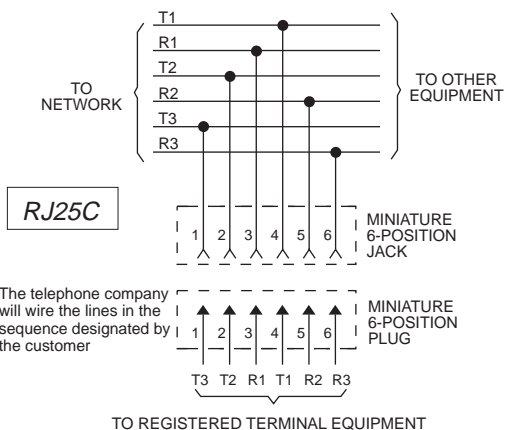

## RJ31X, RJ38X

The FCC has deleted these codes from Part 68. Although not a current USOC number, they continue to appear in common use, especially in security applications.

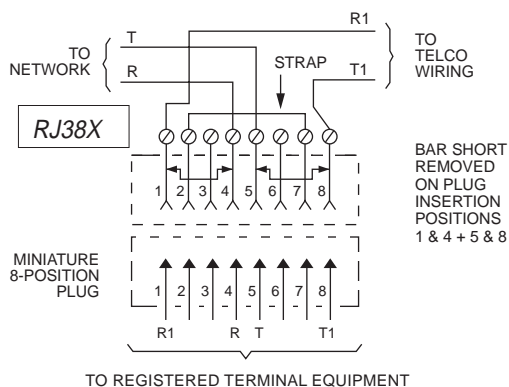

## RJ45S

**Important:** Refer to "note on USOC codes" page 2-8.

**Electrical Network Connection** Single line bridged tip and ring with programming resistor.

**Mechanical Arrangement** Miniature eight-position keyed jack.

**Typical Usage** Connects computers and other data equipment to the telephone network.

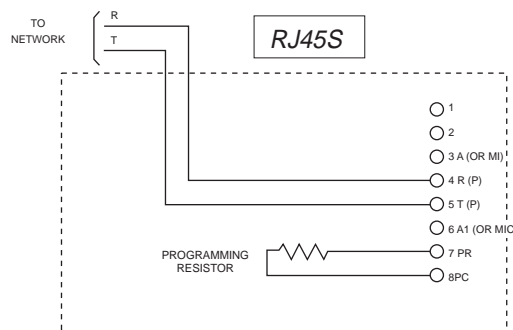

## RJ48C, RJ48S, RJ48X

**Electrical Network Connection:** Two-line tip and ring with shield. Conductors 3 and 6 are reserved for future use.

**Mechanical Arrangement:** Miniature eight-position jack.

**Typical Usage:**

RJ48C/RJ48X 1.54 Mbps digital services  
 RJ48S Local area data channels and subrate digital services

**RJ48X**

*NOTE: RJ48X drawing is provided for information purposes only. No Leviton products support this application.*

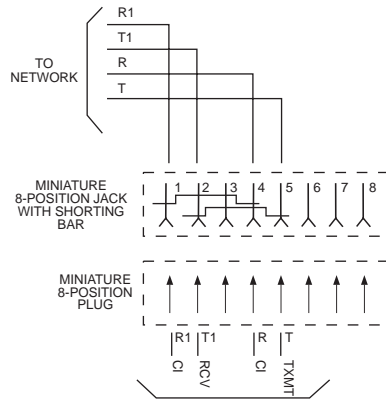

**RJ48C**

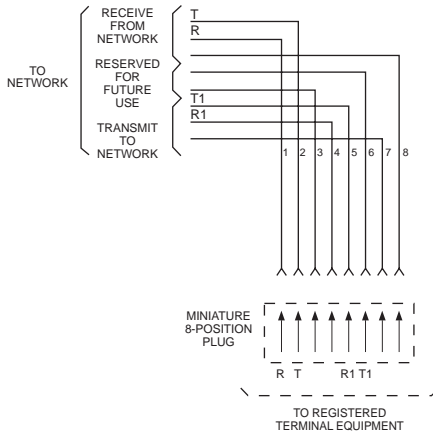

**RJ48S**

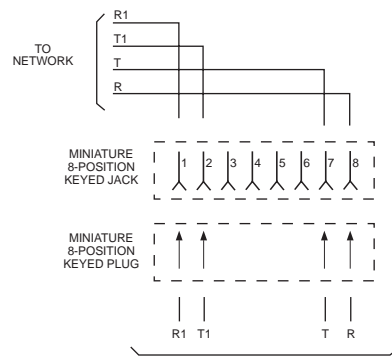

## RJ61X

**Electrical Network Connection:** Up to four line T/R.

**Mechanical Arrangement:** Miniature eight-position modular jack.

**Typical Usage:** Connects up to four lines to a single telephone set or other device. Commonly used for telephones requiring separate power pairs and/or separate signaling pairs.

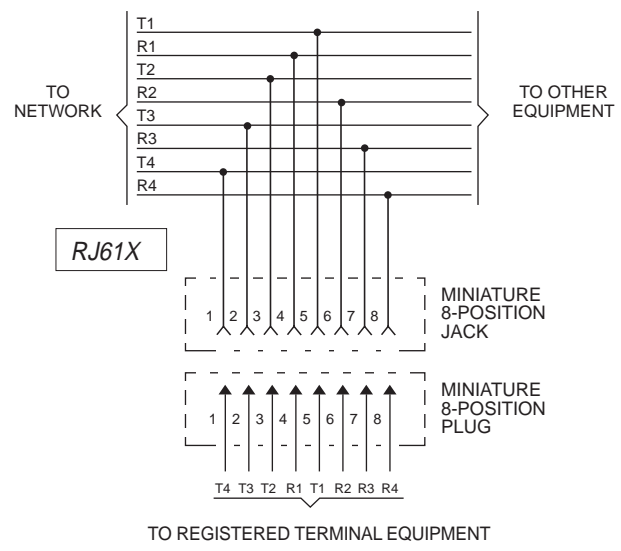

**RJ61X**

A  
P  
P  
E  
N  
D  
I  
X  
  
D  
U  
S  
O  
C  
C  
O  
D  
E  
S

## APPENDIX E CONTACT INFORMATION

The major telecommunications standards documents for voice and data systems are listed here for your reference.

### SAFETY

#### NFPA (National Fire Protection Agency)

- National Electrical Code - 1990 (NEC-1990)

#### UL (Underwriters Laboratories)

- UL 444, Standard for Safety, Communications Cables
- UL 497, Standard for Safety, Protectors for Communications Circuits
- UL 497A, Standard for Safety, Secondary Protectors for Communications Circuits
- UL 497B, Standard for Safety, Protectors for Data Communications and Fire Alarm Circuits
- UL 1459, Standard for Safety, Telephone Equipment
- UL 1863, Standard for Safety, Communication Circuit Accessories

### HARM TO THE TELEPHONE NETWORK

#### FCC (Federal Communications Commission)

- Title 47, Code of Federal Regulations, Part 68
- Docket 88-57

#### Department of Communications (Canada)

- CS-03, Certification Standard, Standard for Terminal Equipment, Terminal Systems, Network Protection Devices, Connection Arrangements and Hearing Aid Compatibility

### PERFORMANCE OF NETWORKS

#### IEEE (Institute of Electrical and Electronic Engineers)

- ANSI/IEEE Std 802.3, Carrier Sense Multiple Access with Collision Detection {Ethernet & 10BASE-T}
- ANSI/IEEE Std 802.5, Token Ring Access Method {Token Ring}

### PERFORMANCE OF WIRING SYSTEMS

#### TIA (Telecommunications Industry Association)

- EIA/TIA-568-A, Commercial Building Telecommunications Wiring Standard
- EIA/TIA-569, Commercial Building Standard for Telecommunications Pathways and Spaces
- EIA/TIA-570, Residential and Light Commercial Telecommunications Wiring Standard
- TIA/EIA-606, Administration Standard for the Telecommunications Infrastructure of Commercial Buildings
- TIA/EIA-607, Commercial Building Grounding & Bonding Requirements for Telecommunications
- TSB-53, Extended Specifications for 150-Ohm STP Cables and Data Connectors
- TSB-67, Link Performance Transmission Specification for Field Testing of Unshielded Twisted Pair Cabling Systems
- PN-2416, Backbone Cabling Systems for Residential and Light Commercial Buildings (In Development)
- PN-3013, Single Mode Optical Fiber Backbone Wiring for Commercial Buildings (In Development)
- PN-3012, Fiber Optic Premises Cabling Guide (In Development)

#### CSA (Canadian Standards Association)

- CAN/CSA-T529, Design Guidelines for Telecommunications Wiring Systems in Commercial Buildings

### CANADIAN SAFETY AND PERFORMANCE

#### CSA (Canadian Standards Association)

- CAN/CSA-C22.2 No. 182.4, Plugs, Receptacles, and Connectors for Communication Systems
- CAN/CSA-C22.2 No. 214, Communications Cables, Wiring Products
- CAN/CSA-C22.2 No. 225, Telecommunication Equipment

## OTHER REFERENCE SOURCES

### ANSI (American National Standards Institute)

### ASTM (American Society of Test Measurement)

#### Bellcore

- PUB 48007, Technical Reference, Inside Wiring Cable (3 to 125 Pair Sizes)

### BICSI (Building Industry Consulting Services International)

8610 Hidden River Parkway  
Tampa, FL 33637-1000  
(800) 242-7405  
(813) 971-4311 (FAX)  
[www.bicsi.org](http://www.bicsi.org)

### CEDIA (Custom Electronic Design & Installation Association)

(800) 669-5329  
[www.cedia.com](http://www.cedia.com)

### ECSA (Exchange Carriers Standards Association)

- Report No.5, A Technical Report on Carrier to Customer Installation Interface Connector Wiring Configuration Catalog

### EIA/CEMA (Electronic Industries Association)

### HAA (Home Automation Association)

#### IBM

- GA27-3773-1, IBM Cabling System Technical Interface Specification ICEA (Insulated Cable Engineers Association)
- ICEA S-80-576, ICEA Standard for Communications Wire and Cable for Wiring of Premises

### ISO/IEC (International Organization for Standardization/International Electrotechnical Commission)

- ISO 8877, Information Processing Systems, Interface Connector and Contact Assignments for ISDN Basic Access Interface Located at Reference Points S and T

### ITU/CCITT (International Telecommunications Union/ International Telegraph and Telephone Consultative Committee)

- Blue Book

## ORDERING INFORMATION

### American National Standards Institute

Sales Department  
American National Standards Institute  
11 West 42nd St 13th Floor  
New York, NY 10036  
Web Site: [www.ansi.org](http://www.ansi.org)  
(212) 642-4900  
(212) 302-1286 (FAX)

### American Society of Test Measurement (ASTM)

1916 Race Street  
Philadelphia, PA 19103-1187  
(215) 299-5585  
(215) 977-9679 (FAX)

#### Bellcore

Bellcore Customer Service  
8 Corporate Place  
Piscataway, NJ 08854-4196  
Web Site: [www.bellcore.org](http://www.bellcore.org)  
(800) 521-CORE (2673)  
(732) 336-2559 (FAX)

### Canadian Standards Association

Standards Sales  
Canadian Standards Association  
178 Rexdale Blvd.  
Rexdale (Toronto), Ontario  
Canada M9W 1R3  
Web Site: [www.csa.ca](http://www.csa.ca)  
(416) 747-4044  
(416) 747-2475 (FAX)

### Department of Communications (Canada)

See Canadian Standards Association

**Exchange Carriers Standards Association**

Exchange Carriers Standards Association  
5430 Grosvenor Lane  
Bethesda, MD 20814

(800) 678-4333  
(732) 981-0027 (FAX)

**Federal Communications Commission**

U.S. Government Printing Office  
Superintendent of Documents  
Mail Stop SSOP  
Washington, DC 20402-9328  
Web Site: [www.fcc.gov](http://www.fcc.gov)  
(888) 225-5322  
(202) 418-0232 (FAX)

**Insulated Cable Engineers Association, Inc.**

PO Box 440  
South Yarmouth, MA 02664  
Web Site: [www.electricnet.com](http://www.electricnet.com)  
(508) 394-4424  
(508) 394-1194 (FAX)

**Global Engineering**

(800) 854-7179 / (800) 624-3974  
Web Site: [www.global.ihs.com](http://www.global.ihs.com)

**International Organization for  
Standardization/International  
Electrotechnical Commission**

See Global Engineering or Phillips Business Info.

Global Engineering  
18201B Mc Durmott West  
Irvine, CA 92714  
(714) 474-3933  
(714) 474-4066 (FAX)

**International Telecommunications Union/  
International Telegraph and Telephone  
Consultative Committee**

See Global Engineering or Phillips Business Info.

Global Engineering  
15 Inverness Way East  
Englewood, CO 80112  
(303) 393-2573  
(303) 397-2740 (FAX)

**National Fire Protection Agency**

National Fire Protection Agency  
Batterymarch Park  
Quincy, MA 02269  
Web Site: [www.opc.com](http://www.opc.com)

Global Engineering  
7730 Carondelet Avenue  
Clayton, MO 63105  
(314) 726-0444  
(314) 726-6418 (FAX)

**Phillips Business Info.**

(Formerly Omnicom)  
1201 Seven Locks Road, Ste 300  
Potomac, MD 20854  
Web Site: [www.phillips.com](http://www.phillips.com)  
(301) 424-3338  
(800) 777-5006  
(301) 309-3847 (FAX)

Global Engineering  
1990 M Street N.W.  
Washington, DC 20036  
(202) 429-2860  
(202) 331-0960 (FAX)

**Telecommunications Industry Association (TIA)**

See Global Engineering

**IBM**

IBM Publications  
P.O. Box 9046  
Boulder, CO 80301-9191  
(800) 879-2755  
(800) 284-4727 (FAX)

**Underwriters Laboratories**

Corporate Progress  
333 Pflugsten Road  
Northbrook, IL 60062-2096  
Web Site: [www.ul.com](http://www.ul.com)  
(847) 272-8800  
(847) 272-8129 (FAX)

**Institute of Electrical and Electronic Engineers**

IEEE Service Center  
445 Hoes Lane  
PO Box 1331  
Piscataway, NJ 08855-1331  
Web Site: [www.ieee.org](http://www.ieee.org)







# ALL THE INFORMATION YOU'LL NEED to help you successfully wire a home or office.

*Includes detailed information on the latest standards practices.*

*Full diagrams on smart wiring runs for telephone, data, audio and security systems in the home.*

*Complete testing and troubleshooting tips.*

*Sections include copper cable wiring for commercial and residential installations including LANs, modems, faxes, audio/video systems and centralized security systems.*

### 3.1.1 STAR TOPOLOGY

**TIA-568-A specifies a star topology: a hierarchical series of distribution levels.** In the backbone are the main distribution frame (MDF) and the optional intermediate distribution frame (IDF). Only one IDF is allowed between the MDF and telecommunications closet.

Fig. 3-1. Typical Commercial Building Wiring Topology

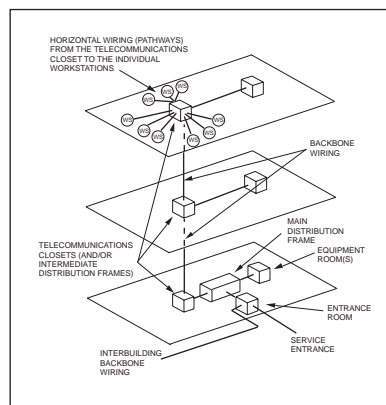

### TERMINATING ONTO 110 BLOCKS

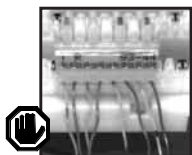

**DON'T** allow pairs to untwist more than the maximum allowed for the cable's Category rating:  
 Above Category 5: <math><1/2''</math> max untwist  
 Category 5: <math>1/2''</math> max untwist  
 Category 4: <math>1''</math> max untwist  
 Category 3: <math>3''</math> max untwist

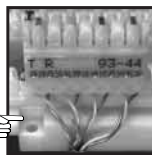

**DO** maintain pair twisting close to the termination point.  
 (Also note that the cable jacket is maintained as close to the termination as possible.)